



LISTEN • DEVELOP • LEAD

**Operation, Installation & Maintenance Manual for
Limited Service Fire Pump Controller
with Automatic Power Transfer Switch**

**Automatic Controller
Model GPL + GLU**



| | |
|---|-----------------------------------|
|  | Table of Contents |
|  | 1. Information |
|  | 2. Installation |
|  | 3. Main Features |
|  | 4. Home |
|  | 5. Alarm |
|  | 6. Configuration |
|  | 7. History |
|  | 8. Technical Documentation |

Table of Contents

| | |
|---|-------------------------------------|
| Introduction..... | 5 |
| Types of Electric Fire Pump Controllers | 5 |
| Types of Automatic Transfer Switch | 5 |
| Methods of starting/stopping | 5 |
| Transfer switch operation Sequence | 6 |
| | |
| Installation | 8 |
| Location..... | 8 |
| Mounting..... | 8 |
| Wiring and Connections | 8 |
| Water Connections..... | 8 |
| Electrical Wiring..... | 8 |
| Electrical Connections..... | 9 |
| Sizing..... | 9 |
| Incoming Power Connections | 9 |
| Incoming Power Connections | 9 |
| Motor Connections | 9 |
| Terminal Strips Descriptions | 10 |
| | |
| Main Features | 12 |
| The ViZITouch..... | 12 |
| First Setup..... | 13 |
| Alarm bell | 13 |
| Quick Start-Up Guide | Error! Bookmark not defined. |
| | |
| Home..... | 14 |
| Home..... | 14 |
| Screen Saver..... | 16 |
| | |
| Alarms | 17 |
| Alarms | 17 |
| | |
| Configuration..... | 21 |
| Config..... | 21 |
| NumPad Page..... | 22 |
| Date and Time Page | 23 |
| User Login Page / Keypad Page | 24 |
| Advanced Configuration Page | 24 |

| | |
|--|----|
| Details of the Advanced Configuration Page | 25 |
| Timers Page | 25 |
| Voltage Calibration | 27 |
| Current Calibration | 27 |
| Inputs/Outputs Expansion board 1-2-3-4 | 28 |
| Update Program Page | 29 |
| Factory Settings | 29 |
| Reset to Factory Settings Page | 33 |
| Service Page | 34 |
| New Pump Curve | 35 |
| Automatic Pump Curve Mode Disabled | 36 |
| The Sensors Pages..... | 37 |
| Details of the Debug Page | 40 |
| Calibration | 40 |
| IO Debug..... | 41 |
| | |
| History | 43 |
| History | 43 |
| Details of the History Page..... | 44 |
| Events Page | 44 |
| Download to USB Device..... | 44 |
| The Statistics..... | 46 |
| First/Last Service Statistics..... | 46 |
| All Time Statistics..... | 47 |
| Pressure Curves..... | 47 |
| Graphical Mode..... | 47 |
| Textual Mode..... | 48 |
| Power Curves..... | 49 |
| Graphical Mode..... | 49 |
| Textual Mode..... | 50 |
| Pump Curves..... | 51 |
| | |
| Technical Documents..... | 52 |
| Pre-field Acceptance Test..... | 53 |
| Field Acceptance Test Report..... | 55 |

Introduction



Model GPL+GLU limited service fire pump controllers are designed to start an electric motor driven fire pump. It can either start the fire pump manually through the local start pushbutton or automatically through the sensing of a pressure drop in the sprinkler system. The fire pump controller is supplied with a pressure transducer. The fire pump can be stopped manually with the local stop pushbutton or automatically after the expiration of a field programmable timer. In both cases, stopping is only allowed if all starting causes have disappeared.

Types of Electric Fire Pump Controllers

LIMITED SERVICE FIRE PUMP CATALOGUE NUMBER

| MODEL n° EXAMPLE: GPL - 208 / 20 / 3 / 60 | |
|---|-------|
| Model Prefix | GPL |
| Voltage | 208 V |
| HP Rating | 20 HP |
| Phase | 3 |
| Frequency | 60 Hz |

ACROSS-THE-LINE STARTER

This model is intended to be used where the local utility or the capacity of the power source permits across-the-line starting. Full voltage is applied to the motor as soon as the controller receives a start command

Types of Automatic Transfer Switch

TRANSFER SWITCH CATALOGUE NUMBER

| MODEL n° EXAMPLE: GLU - 208 / 20 / 3 / 60 | |
|---|-------|
| Model Prefix | GLU |
| Voltage | 480 V |
| HP Rating | 20 HP |
| Phase | 3 |
| Frequency | 60 Hz |

Methods of starting/stopping

The controllers are available as a combination automatic / non-automatic with provision for manual or automatic shutdown (automatic shutdown only possible after automatic start)

METHODS OF STARTING

AUTOMATIC START

The controller will start automatically on low pressure detection by the pressure sensor when pressure drops below the cut-in threshold. The controller must be in automatic mode.

MANUAL START

The motor can be started by pressing the START push button, regardless of the system pressure.

REMOTE MANUAL START

The motor can be started from a remote location by momentarily closing a contact of a manual push button.

REMOTE AUTOMATIC START, DELUGE VALVE START

The motor can be started from a remote location by momentarily opening a contact connected to an automatic device. The controller must be in automatic mode.

EMERGENCY START

The motor can be started manually by using the emergency handle. This handle can be maintained in a closed position.

Important: to avoid damaging the contactor, it is recommended to start the motor in this manner:

- 1) Shutdown the main power by using the main disconnect means,
- 2) Pull the emergency handle and lock it in closed position,
- 3) Turn the power back on by using the main disconnect means.

SEQUENTIAL START

In case of multiple pump application, it may be necessary to delay the automatic (pressure drop) starting of each motor to prevent simultaneous starting of all motors.

FLOW START, HIGH ZONE START

The controller can be started by opening/closing a contact on the FLOW/ZONE START/STOP input.

WEEKLY START

The motor can be started (and stopped) automatically at the preprogrammed time.

TEST START

The motor can be started automatically for a preprogrammed time by pressing the run test button.

METHODS OF STOPPING

MANUAL STOP

Manual stop is done by pressing the priority STOP push button. Note that pressing the stop push button will prevent the motor from restarting as long as the button is pressed, plus a two seconds delay.

AUTOMATIC STOP

Automatic stop is possible only after an automatic start and this function must be activated. When this function is enabled, the motor is automatically stopped 10 minutes after the restoration of the pressure (above the cut-out threshold) given that no other run cause is present.

FLOW STOP, HIGH ZONE STOP

If the controller has been started by the FLOW/ZONE START/STOP input and that the signal has returned to normal, the motor will be stopped given that no other run cause is present.

EMERGENCY STOP

The emergency stop is always possible in any starting conditions and is done by using the main disconnecting means located on the door.

Transfer switch operation Sequence

TRANSFER TO ALTERNATE POWER SOURCE

The Transfer to Alternate Power Source starts automatically when at least one of the following conditions are present:

- Normal Power voltage falls below 85% of nominal voltage,
- Normal Power Phase Reversal is detected,
- Transfer Switch Test push button is pressed.

When an under voltage condition on any phase of the Normal Power source is detected by the sensor the 3 second normal power source outage delay timer starts counting.

If the normal source voltage rises above the sensor dropout setting before the 3 second time delay expires, the

transfer sequence is cancelled.

If the Normal Power source voltage is still below the sensor dropout setting (85%) when the time delay expires, the relay is deactivated to start the generator set. At the same time, a voltage and frequency sensor begins monitoring the Alternate Power Source. The sensor will accept the alternate power source only when both voltage and frequency reach pre-set pickup value. An approximate 15 second time span occurs because the engine-driven generator cranks, starts and runs up to nominal pickup value.

When the Alternate Power Source is within acceptable limits (above 90% of the nominal voltage) for an alternate available delay (factory set at 3 seconds), the transfer to alternate power source is initiated.

The transfer switch will remain in the alternate power source position until the normal source is restored.

RETRANSFER TO NORMAL

Important: the transfer switch stays in alternate position if motor is running for as long as the alternate power source is within acceptable limits. Retransfer sequence is enabled if motor is not running.

The Retransfer to the Normal Power source starts when the voltage sensor detects restoration of the Normal Power Source within acceptable limits. The voltage level must rise above the pre-set pickup value (90%) on all phases before the sensor will accept the normal source.

When the normal source is accepted by the sensor, the retransfer to normal delay timer starts counting (factory set at 5 minutes). This delay can be by-passed by pressing on the count-down timer displayed on screen (if a flashing "X" is displayed).

This delay prevents immediate load retransfer to the normal source. The delay insures that the normal source has stabilized before reconnection of Fire Pump Motor. If the normal source voltage falls below the pre-set dropout value before the time delay expires, the timing cycle is reset to zero. If the alternate power source fails during the timing cycle, the load is immediately retransferred to the normal source, if that source is acceptable.

The Automatic Transfer Switch is now feeding the Fire Pump Motor from the Normal Power Source again.

Upon retransfer to the normal source, the 5 minute cooling timer starts counting to keep the engine running for a cool-down period. This delay can be by-passed by pressing on the count-down timer displayed on screen (if a flashing "X" is displayed). After the time delay, the relay is re-activated to shut down the engine-driven generator. All circuits are reset for any future normal source failure.

Every time the transfer switch needs to change from one power source to the other, a running motor is stopped during the transfer to prevent instant across the line starting of an already turning motor. If the motor still needs to run when the transfer sequence has completed (plus a factory set 2 seconds timer), the motor will be restarted following its default startup sequence.



Installation

The GPL+GLU limited service electric fire pump controller is listed cULus, FM and is intended to be installed in accordance with the Standard of the National Fire Protection Association for the Installation of Centrifugal Fire Pumps, NFPA n°20-2010 (Centrifugal Fire Pumps) and

| | |
|-----------|----------------------------------|
| in USA | National Electrical Code NFPA 70 |
| in Canada | Canadian Electrical Code, Part 1 |
| others * | Local Electrical Codes * |

*Only American and Canadian applicable codes have been considered during the design of the controllers and the selection of components.

Location

The controller shall be located as close as practical to the engine/motor it controls and shall be within sight of the engine/motor. The controller shall be located or protected that it will not be damaged by water escaping from pump or pump connections. Current carrying parts of controller shall be not less than 12 in. (305 mm) above the floor level. Working clearances around controller shall comply with NFPA 70, National Electrical Code, Article 110 or C22.1, Canadian Electrical Code, Article 26.302 or other local codes.

The controller is suitable for use in locations subject to a moderate degree of moisture, such as a damp basement. The pump room ambient temperature shall be between 41°F (5°C) and 104°F (40°C).

The standard controller enclosure is rated NEMA 2. It is the installer's responsibility to insure that either the standard enclosure meets the ambient conditions or that an enclosure with an appropriate rating has been provided.

Controllers must be installed inside a building and they are not designed for outside environment. The paint color may change if controller is exposed to ultraviolet rays for a long period of time.

Mounting

The fire pump controller shall be mounted in a substantial manner on a single incombustible supporting structure. Wall mounted controller shall be attached to the structure or wall using all four (4) mounting ears provided on the controller with hardware designed to support the weight of the controller at a height not less than 12 in. (305 mm) above floor level. Floor mounted controller shall be attached to the floor using all holes provided on the mounting feet with hardware designed to support the weight of the controller. The mounting feet provide the necessary 12 in. (305 mm) clearance for current carrying parts. A concrete slab is recommended to avoid water accumulation at the controller's feet.

Wiring and Connections

Water Connections

The controller must be connected to the pipe system according to NFPA20-2010 and also to a drain pipe. The water connections are on the left side of the controller. The connection to the system pressure is a Male ½ NPT. The connection to the drain is a tapered connection for plastic tubing.

Electrical Wiring

The electrical wiring between the power source and the fire pump controller shall meet the NFPA 20-2010, Chapter 9-3, NFPA 70 National Electrical Code Article 695 or C22.1 Canadian Electrical Code, Section 32-200 or other local codes. Electrical wiring shall be typically sized to carry at least 125% of the full load current of the fire pump motor.

Electrical Connections

A licensed electrician must supervise the electrical connections. The dimension drawings show the area suitable for incoming power and motor connections. No other location shall be used. Only watertight hub fittings shall be used when entering the cabinet to preserve the NEMA rating of the cabinet. The installer is responsible for adequate protection of the fire pump controller components against metallic debris or drilling chips. Failure to do so may cause injuries to personnel, damage the controller and subsequently void warranty.

Sizing

Incoming power terminals on the controller are suitable to accept wire based on that selection with insulation not less than 60°C. (Refer to terminal diagram for terminal sizes.)

The electrical wiring between the fire pump controller and the pump motor shall be in rigid, intermediate, or liquid tight flexible metal conduit or Type MI cable and meet the requirements of NFPA 70 National Electrical Code or C22.1 Canadian Electrical Code or other local codes.

The number of conductors required is 3-wires plus ground sized at 125% of full load current.

Incoming Power Connections

Incoming normal power is to be connected to terminals identified L1-L2 and L3 located on the disconnecting means IS. The electronic board is phase sensitive, thus the incoming power leads must be connected in the correct phase order.

Incoming Power Connections

Incoming normal power is to be connected to terminals identified L1-L2 and L3 located on the disconnecting means IS. For the transfer switch, incoming alternate power is to be connected to terminals identified AL1-AL2-AL3 located on the disconnecting means AIS (transfer switch side). The electronic board is phase sensitive thus the incoming power leads must be connected in the correct phase order.

Motor Connections

Motor connections are connected to terminals identified by:

- T1-T2 and T3 located on main contactor (1M).

It is the responsibility of the installer to obtain connection information on the motor and to assure that the motor is connected as per motor manufacturer recommendations. Failure to do so may cause injuries to personnel, damage the motor and/or the controller and subsequently void warranty on both items.

Terminal Strips Descriptions

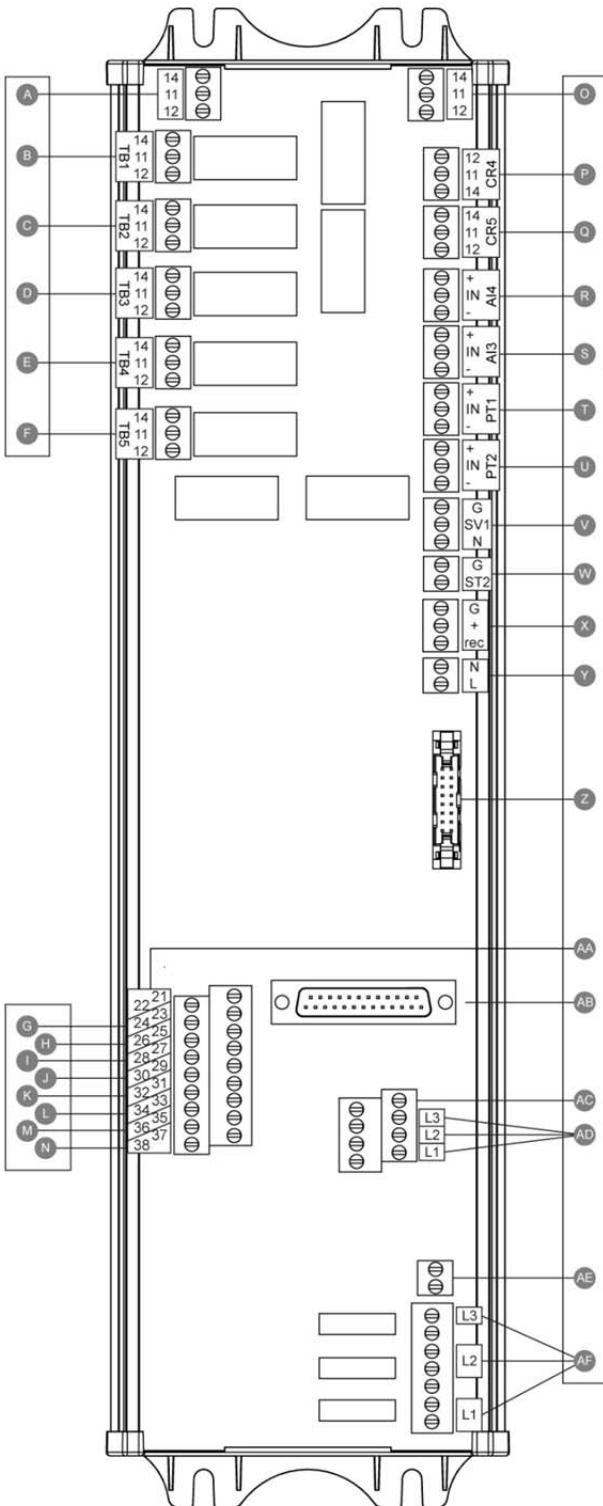

Alarm outputs terminals (SPDT Relay, 11:Common, 12:Normally Closed, 14:Normally Opened):

- A Motor Run
- B Power Available (Failsafe relay)
- C Phase Reversal
- D Pump Room Alarm
- E Motor Trouble
- F Factory Reserved

Field inputs terminal (Dry Contact Only: Voltage Free):

- G Remote Manual Start (NO)
- H Lockout (NO)
- I Remote Automatic Start (NC)
- J Deluge Valve (NC)
- K Factory Reserved 3 (NO)
- L Flow/Zone Start/Stop (NO)
- M Factory Reserved 2 (NO)
- N Factory Reserved 1 (NO)

Factory IO:

- O Motor Run auxiliary contact
- P Main Coil power relay
- Q Delay Coil power relay
- R Water Level/Suction Pressure sensor
- S Spare Temperature/Flow sensor
- T PT1 Discharge Pressure sensor
- U PT2 Discharge Pressure sensor (redundant opt. only)
- V Test Solenoid Valve
- W Shunt Trip
- X Factory Reserved
- Y 24VAC input power
- Z CANBUS to IO cards
- AA Emergency Handle limit switch
- AB CANBUS to ViZiTouCh
- AC Ground Fault
- AD Input Current sensing
- AE Ground
- AF Input Voltage sensing

Terminal Strips Descriptions

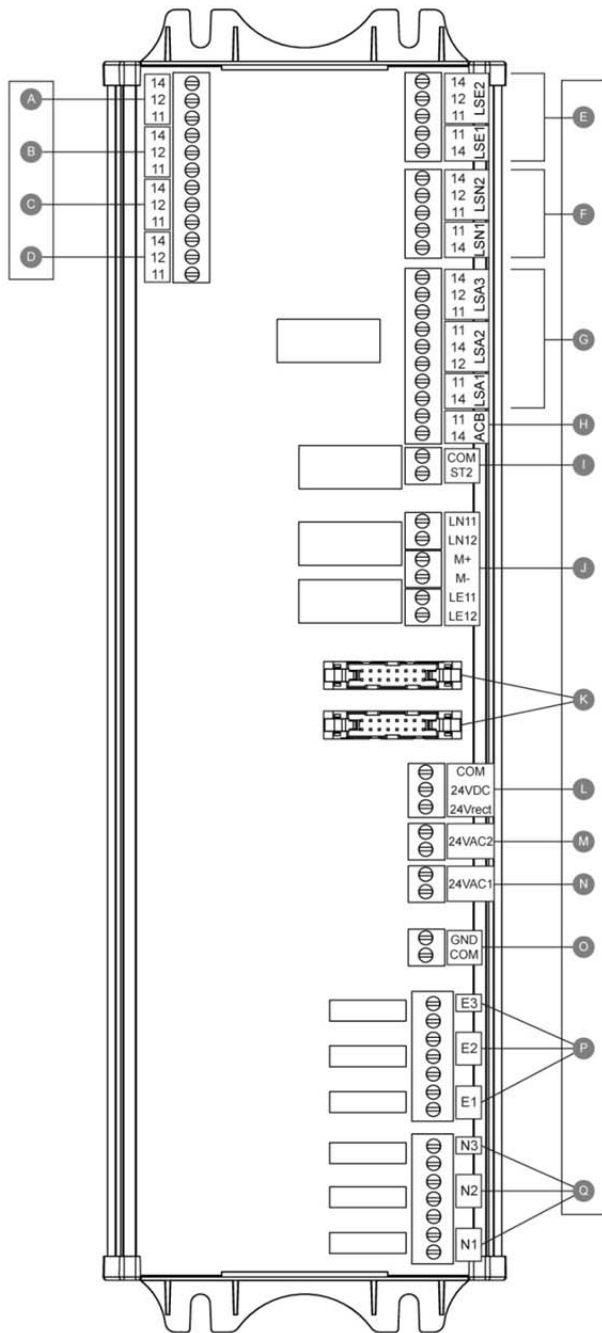

Outputs terminals:

- A Transfer Switch in Alternate Position
- B Transfer Switch in Normal Position
- C Alternate Circuit Breaker
- D Generator Signal

Factory IO:

- E Alternate limit switches
- F Normal limit switches
- G AIS/ACB limit switches
- H ACB limit switch
- I ACB shunt trip
- J Transfer Switch motor
- K CANBUS to IO cards
- L Factory Reserved
- M 24VAC input power 2
- N 24VAC input power 1
- O Ground
- P Alternate Input Voltage sensing
- Q Normal Input Voltage sensing



Main Features

The ViZiTouch

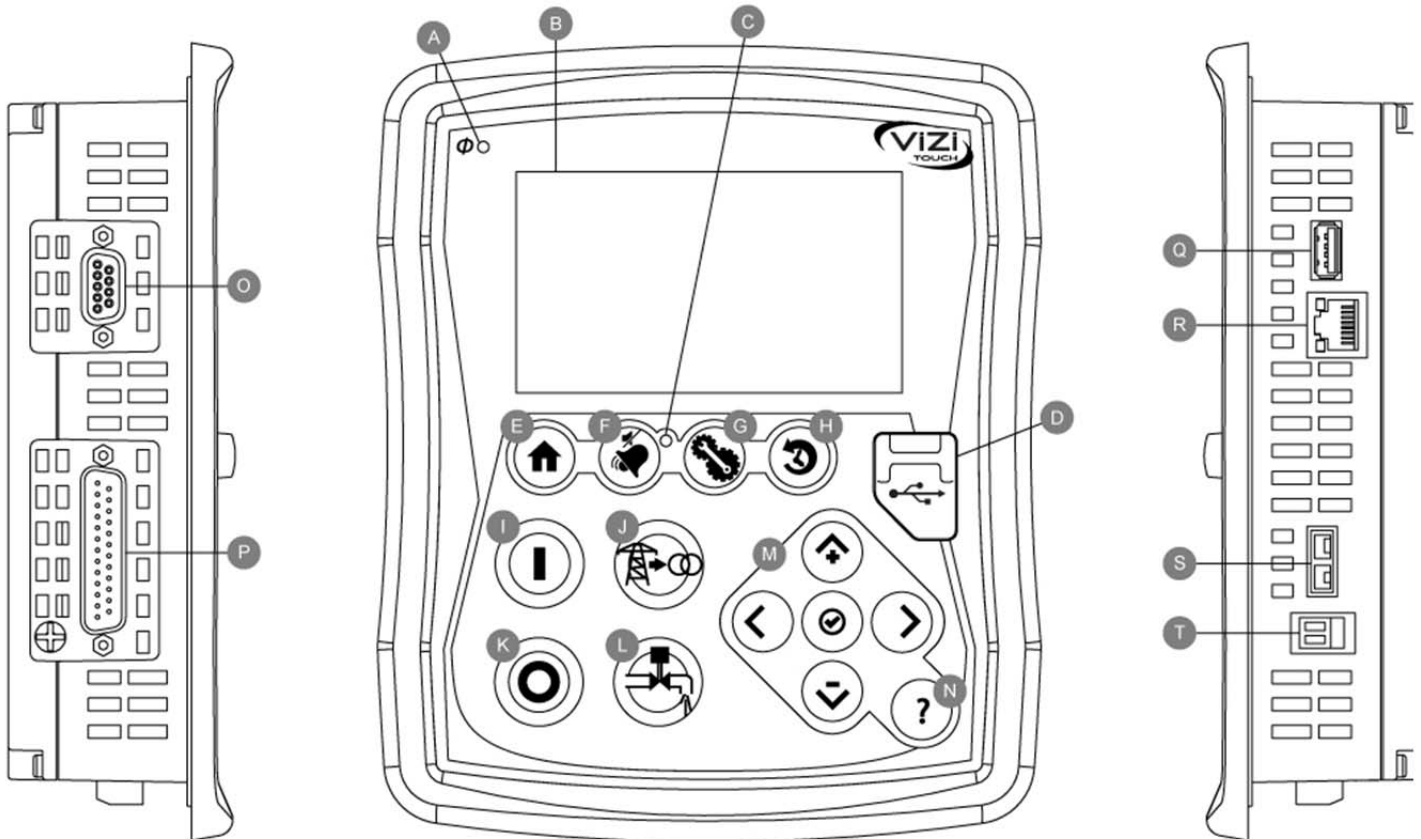

- A: Power Available LED:** Indicates that power is available
- B: Touch Screen:** 4.3 inches color touch screen LCD
- C: Alarm LED:** Indicates if an alarm is active
- D: Front USB Connector:** USB Device connector used for files download, software update, service reports
- E: Home button:** Used to navigate to the Home page
- F: Alarm button:** Used to navigate to the Alarm page. It also allows the user to silence the alarm bell, hence the small “no speaker” symbol
- G: Config button:** Used to navigate to the Configuration page
- H : History button:** Used to navigate to the History page
- I: Start button:** Used to manually start the motor
- J: Transfer Switch Test Button:** Used to test the transfer switch sequence.
- K: Stop button:** Used to stop the motor
- L: Run Test button:** Used to start the manual run test. Be aware that water will flow through the drain with models equipped with a solenoid valve.
- M: Contextual navigation pad:** Used to facilitate the navigation on specific pages. A small icon representing the contextual navigation pad will appear at the bottom right corner of a page if the pad is active. By clicking on the small

pad icon, a menu explaining the specific functions of the arrows will appear. For example, it is possible to switch between the graphical or the table mode on the logs page, as well as navigate through the tables or the help pages.

N: Help button: The help button is context sensitive, meaning that it will always show the specific help page linked to the actual ViZiTouch page that was selected when the button was pressed.

O: RS-485 connector

P: CAN bus connector to IO cards

Q: USB 2.0 connector

R: Ethernet connector

S: K-Type Thermocouple connector

T: Alarm Bell connector

First Setup

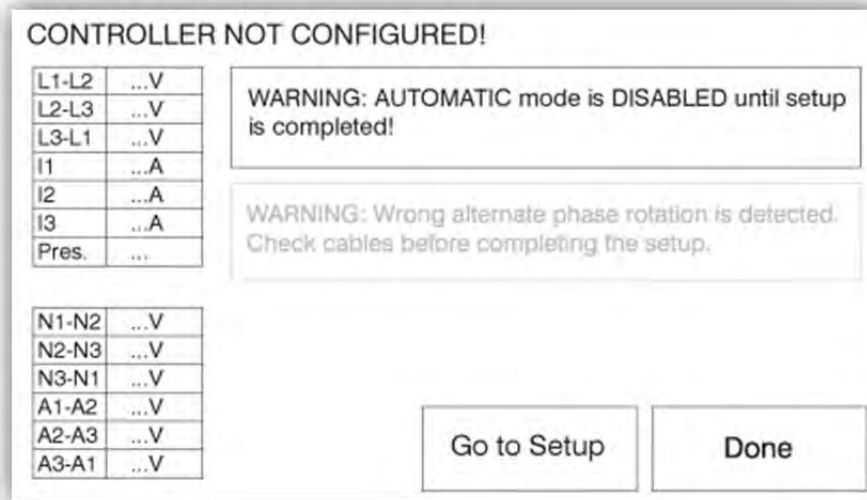

The first Setup must be done prior to using the controller. Completing the First Setup is the only way to access the homepage and enable the automatic mode of the controller.

Alarm bell

The alarm bell is activated under default condition and under optional or user defined conditions.

Any of these conditions will energize the alarm bell but may be silenced, except in some cases, by pressing on the "Alarms / silence" membrane button. When silenced, the alarm bell restarts ringing if a new default occurs or if the alarm conditions remain unchanged after 24 hours. The alarm bell automatically stops ringing if alarm conditions are not present anymore.

Note: other external conditions may trigger optional conditions depending of the factory settings. Verify drawings affixed inside the cabinet.

Default Conditions :

- IO Cards Communication Loss
- CAN System Failure
- File System Failure
- IO Cards Communication Loss
- CAN System Failure
- File System Failure
- Alternate Isolating Switch / Circuit Breaker Off / Tripped*



Home

Home (Membrane button)

Home

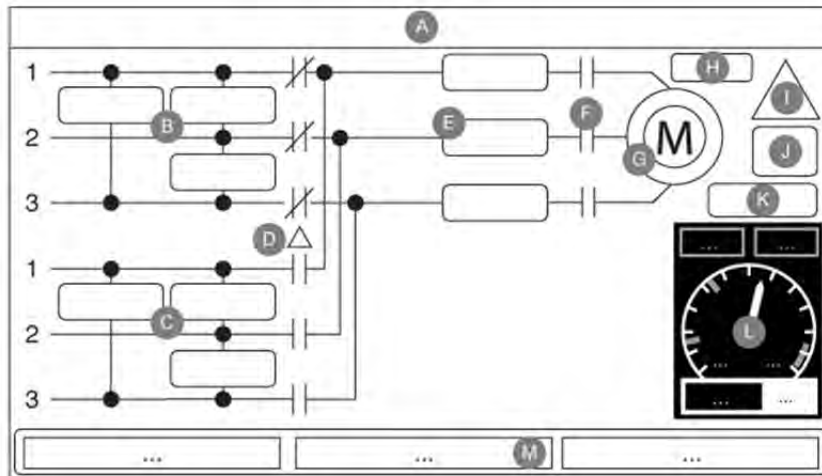

The home page displays all controller statuses and important values of the controller. All voltages, currents, pressure, motor state and status, as well as all timers and motor starting sequences.

The entire background will become red if an alarm becomes active. This feature will help the user identify a problem even from a significant distance away from the controller.

- A:** Navigation bar which contains general information about:
- The language (the language may be changed by pressing on it)
 - The page title
 - The alarm banner (warning and alarm messages may be shown)
 - The date and time (adjustable in the Configuration page)
 - The temperature. It can be changed to Celsius or Fahrenheit by pressing on it.

B: Normal power voltage. Each box represents an individual phase voltage between the two adjacent lines.

B: Alternate power voltage. Each box represents an individual phase voltage between the two adjacent lines.

D: The transfer switch position is represented here by the form of contactors switching the desired power lines.

E: Current. Each box represents an individual phase current between the two adjacent lines.

F: Motor contactors. An animation shows the contactor opened or closed depending on the signal sent to the main coil.

G: The electric motor. It will be grey if the engine is stopped, green if a "Motor Run" signal is detected and red if a "Fail to start" occurred. Pressing on the engine will redirect the user to the "Last Service Statistics" page, which monitors all relevant statistics concerning the controller since the last service.

H: Timers. Sequential start timer (on-delay) will start counting upon a pressure drop. The motor will only start if the

pressure is still below the start point after the expiration of this timer. The minimum run period timer (off –delay) for automatic shutdown will start counting once the stop pressure is reached. The pump will stop at the expiration of this timer if the pressure is still above the stop pressure. If a periodic test has been programmed, the remaining time will be displayed. If a manual run test has been energized, the remaining time will be displayed.

I: The alarm/warning notification.

Warning indicator: Exclamation mark in a yellow round icon. If no alarm is in ACTIVE condition on the controller and at least one warning is ACTIVE or OCCURRED, the warning indicator will be present.

Alarm indicator: Exclamation mark in a red triangle icon. As soon as at least one alarm is ACTIVE or OCCURRED, the alarm indicator will be flashing.

J: The motor configuration symbol shows how the motor is wired to the contactor(s). This symbol is used to show the permanent running configuration (i.e. delta wiring)



Permanent delta motor connection.

K: Representation of the motor starting or stopping cause. A green capsule will indicate the reason why the motor is running. Possible choices are:

EMERGENCY: Manual motor starting activated by the emergency handle.

MANUAL: Manual motor starting activated by the START push button.

REMOTE MANUAL: Manual motor starting activated by a remote start contact.

DELUGE: Automatic motor starting activated by a deluge valve.

AUTO: Automatic motor starting activated by pressure drop

REMOTE AUTO: Automatic motor starting activated by remote equipment

FLOW: Automatic motor starting activated by a signal in the FLOW/ZONE START/STOP input.

HIGH ZONE: Automatic motor starting activated by a signal in the FLOW/ZONE START/STOP input.

WEEK TEST: Automatic motor starting activated by a scheduled test.

MANUAL TEST: Automatic motor starting activated by the run test push button.

A red capsule will indicate the reason why the motor is not running despite the fact that a request is being made. Possible choices are:

LOAD SHED: The transfer switch has transferred to the alternate position and the motor starting is delayed to reduce the load on the alternate power source. This functionality is optional.

LOCK ROTOR CURRENT: A lock rotor current alarm has not been cleared on the alarms page and prevents the motor from starting.

LOW PRESSURE: A low suction pressure prevents the motor from running, This functionality is optional.

LOW WATER: A low water reservoir level prevents the motor from running, This functionality is optional.

TRANSFER STOP: The transfer switch is transferring between power source and the motor is temporarily stopped in the process.

LOW ZONE: A not running lower zone controller prevents the motor from running. This functionality is

optional.

LOCKED: An interlock signal is preventing the motor from running.

L: The discharge pressure gauge. It allows for a precise reading of the actual system pressure. The red box on the upper left corner of the gauge indicates the value of the Cut-In set point and the green box on the upper right corner represents the Cut-Out set point. These values will also be represented by a red and green line on the gauge, allowing a quick comparison between the actual pressure and the set points. At the bottom of the gauge, a digital indicator shows the actual discharge pressure represented also by the needle of the gauge. To the right of the digital pressure indicator, the actual pressure unit is shown. Finally, the maximum allowable pressure is also indicated on the gauge and will scale the gauge accordingly.

M: Displays three statuses that describe the primary configuration of the controller: Pressure actuated or Non-pressure Actuated, Automatic Controller or Non-automatic, Manual or Automatic Shutdown.

Screen Saver

The screen saver appears after a programmable amount of time set on one of the “Factory Settings” page. Its goal is to expand the lifetime of the LCD screen. The screen saver will be instantly deactivated if the engine is running or if an alarm is activated. To manually deactivate it, simply touch the screen or any membrane button. After deactivation, the screen saver will always redirect to the “Home” page. It will also log off any user by resetting the security level to 0.

Alarms



Alarms (Membrane button)

Alarms

| Alarms | | | | |
|--------|------|------|-------|-------|
| | Date | Time | Alarm | State |
| 1 | | | | |
| 2 | | | | |
| 3 | | | | |
| 4 | | | | |
| 5 | | | | |
| 6 | | | | |
| 7 | | | | |
| 8 | | | | |
| 9 | | | | |

Reset

Displays the list of currently active and occurred alarms. An alarm is called ACTIVE when its triggering condition is still valid. An alarm is called OCCURRED when its triggering condition has been active, but is no longer true. Alarms representing serious concerns are colored RED. Alarms representing simple warnings are colored YELLOW. To silence the bell press the ALARM button or it will silence itself after the expiration of a factory set timer. Pressing on the RESET button will reset OCCURRED alarms only. Alarms ending with ** are available on transfer switch models only.

The table displays system events:

- Date and Time: Date and time stamp of the alarm in the YYYY.MM.DD format
- Message: Alarm message
- State: OCCURRED or ACTIVE
- Color Code:
 - Red: The event is an alarm
 - Yellow: The event is a warning

Complete list of alarms :

- Normal Phase Reversal: Activates when the phase order on the normal power does not match the correct value of the controller. Each time a service is acknowledged on the ViZiTouch, the controller synchronises the correct phase order to the one detected on the normal power.
- Alternate Power Phase Reversal**: Activates when the phase order on the alternate power does not match the correct value of the controller. Each time a service is acknowledged on the ViZiTouch, the controller synchronises the correct phase order to the one detected on the normal power.

- Phase Loss N1: This alarm is activated if the first phase of the normal power connection does not meet the qualification criteria.
- Phase Loss N2: Activates if the second phase of the normal power connection does not meet the qualification criterions.
- Phase Loss N3: Activates if the third phase of the normal power connection does not meet the qualification criterions.
- Loss of power: Activates when a complete loss of normal power is detected.
- Lock Rotor Current: Activates when a locked rotor condition has been detected on the normal power. Note that the motor will not be permitted to start on the normal power as long as this alarm has not been reset from the alarms page.
- Alternate Lock Rotor Current**: Activates when a locked rotor condition has been detected on the alternate power. Note that the motor will not be permitted to start on the alternate power as long as this alarm has not been reset from the alarms page.
- Fail to start: Activates if there is and under-current draw of two phases when the motor should be running. A 20 seconds factory set delay is used to give the motor enough time to start before signalling this alarm.
- Transfer Switch Trouble**: Activates upon detection of any of the following incoherent transfer switch data: The alternate position and normal position limit switches are both activated. None of the alternate position or the normal position limit switches are activated for a factory programmed delay. The voltage reading on the motor contactor does not match the one of the reported input power position for a factory programmed delay.
- Service Required: Activates when service is due for the controller. This occurs when the date set in the service page has passed or if no service has ever been done.
- Undercurrent: Activates when current is under 30% of FLA and motor has been running for 15 seconds.
- Overcurrent: Activates when current is above 120% of FLA.
- Under voltage: Activates when normal power voltage is below 80% of nominal voltage.
- Over voltage: Activates when normal power voltage is above 120% of nominal voltage.
- Phase Unbalanced: Activates when there is a difference of more than 30% of nominal voltage between the normal power voltage readings.
- Ground Fault: Activates when the ground fault input current is above the factory set value for a factory set delay.
- WT CI Not Reached: Activates if the Cut-In is not reached during a manual run test or a weekly test timer. At the end of the 255s timer, if the Cut-In is not reached, the test may still be successful at starting the motor if the pressure has dropped by at least 5 PSI.
- WT Check WT Solenoid: Activates if the pressure does not drop a minimum of 5 PSI during the manual run test or the weekly test. Indicates a failure with the Test Solenoid Valve.
- PT Fault Detected: If an optional dual pressure sensor is installed, it will be activated if the two pressure transducers show different readings. Further investigation is advised to determine what caused the different readings. Note that the controller will always choose the lowest pressure reading to determine the actual system pressure.
- Overpressure: Activates if the analog readout of the discharge pressure goes higher than the overpressure set point in the discharge pressure sensor page.

- Underpressure: Activates if the analog readout of the discharge pressure goes lower than the “Under Pressure” set point in the discharge pressure sensor page.
- Low Suction Pressure: Activates if the analog readout of the suction pressure is enabled and goes lower than the low suction pressure set point in the suction pressure sensor page.
- Force start on flow: Activates if an external contact triggers flow switch input or if the analog readout of the flow is enabled and goes higher than the flow force start on flow set point in the flow sensor page.
- Low Spare Temperature: Activates if the analog readout of the spare temperature input is enabled and is lower than the low spare temperature set point in the “Spare temperature” sensor page.
- Alternate Isolating Switch Tripped/Opened**: Activates when the AIS is either tripped or opened. This alarm condition rings the bell and cannot be silenced.
- Alternate CB Tripped/Opened**: Activates when the ACB is either tripped or opened. This alarm condition rings the bell and cannot be silenced.
- Water Reservoir Low: Activates if the “Water Reservoir Low” contact input is triggered or if the analog readout of the water reservoir is enabled and is lower than the water reservoir low set point in the “Water Level” sensor page.
- Water Reservoir Empty: Activates if an external contact triggers the optional “Water Reservoir Empty” input.
- High Water Level: Activates if the optional “High Water Level” contact input is triggered or if the analog readout of the water level is enabled and goes higher than the “High Water Level” set point in the “Water Level” sensor page.
- Main Relief Valve Open: Activates if an external contact triggers the optional “Main Relief Valve Open” input.
- Io_expX-inX alarm: Activates if the specific expansion programmable input on the specific expansion board is activated and triggered.
- High Motor Temperature: Activates when the optional high motor temperature contact is activated.
- High Motor Vibration: Activates when the optional high motor vibration contact is activated.
- Low ambient temperature: Activates when the ambient temperature is below the factory set value (5 Celsius).
- High ambient temperature: Activates when the ambient temperature is above the factory set value (40 Celsius).
- Control Voltage Not Healthy: Activates when the 24VAC power input to the IO cards is below the acceptable functional range.
- Soft Starter Fault: Activates when a solid state starter is in fault (for GPS models only).
- Motor Trouble: Activates when a motor related alarm condition is present (overcurrent, undercurrent, fail to start or ground fault).
- Pump Room Alarm: Activates when a pump room related alarm condition is present (overvoltage, undervoltage, phase unbalanced).
- Flow Meter On: Activates when the optional flow meter input is activated.
- IO Electric Communication Error: Activates if no communication with the electric IO card could be established for 15 seconds. This alarm is critical and triggers the bell. If this alarm persists for more than 1 minute, the controller will reboot to try and fix the problem.
- IO Transfer Switch Communication Error**: Activates if no communication with the transfer switch IO card

could be established for 15 seconds. This alarm is critical and triggers the bell. If this alarm persists for more than 1 minute, the controller will reboot to try and fix the problem.

- IO Expansion Communication Error: Activates if no communication with the Expansion IO card could be established for 15 seconds.
- Communication System Failure: Activates when the communication task has stopped responding. This alarm condition is critical and the controller will reboot to try and fix the problem.
- File System Failure: Activates when a file system error was detected. This alarm condition is critical and the controller will reboot to try and fix the problem.
- Pump on demand: Activates when the pressure is below the cut-in set-point on an automatic pressure actuated controller.

Configuration



Config (Membrane button)

Config

The screenshot shows a configuration screen titled "Config". It is divided into several sections:

- Pressure**: A section with four input fields labeled "Units", "Max. Pres.", "Cut-Out", and "Cut-In".
- Duration(m)**: A section with a checkbox, a numeric input field, and a colon separator.
- Run Test Duration (m)**: A section with a numeric input field and a circular gauge.
- Automatic Shutdown (m)**: A section with a checkbox and a numeric input field.
- Service**: A button with a clock icon.
- Advanced**: A button.
- Padlock**: A padlock icon at the bottom right, indicating the current authorization level.

Setup all basic configuration parameters.

The main configuration page provides a quick means of changing the most common settings. The padlock icon indicates the current authorization level. A locked padlock indicates that only basic settings can be changed. Press on the padlock to enter an authorization code to unlock additional settings. An unlocked padlock showing an authorization number indicates that some settings are unlocked. Press on the padlock again when you have concluded your operation.

Access Level 0:

- The "Advanced" button activates the advanced configuration pages.
- Date and Time adjustment are accessed by pressing the clock. Refer to the "Date and Time" page for more information.

Access Level 1:

Inside the left box, the main pressure parameters can be set.

- Adjustment of the pressure reading "Unit of measure": PSI, kPa, bar, FoH, mH2O
- Maximum pressure of system (between the Cut-Out value and 9999)
- Cut-Out adjustment (between the Cut-Out value and the Maximum Pressure value). It should be set before setting the Cut-In
- Cut-In adjustment (between 0 and the Cut-Out value)

Inside the middle box, the parameters linked to the different tests can be set. To activate the weekly test, press the white square at the left of the weekly test frequency. When activated, the square turns green. The “Weekly Test Frequency” is the text field just right of the activation square button. By clicking on it, a selection Pad will provide three choices for the frequency of the periodic test: “Weekly Test”, “Bi-Weekly Test” and “Monthly Test”.

The next set of parameters is the periodic test schedule which consists of three editable fields. The first field is the day of the week and the time, in hours and minutes. Simply press the appropriate button to set these values accordingly. The next editable field located just below is the periodic test duration in minutes. The last section of the middle box is the duration of the manual “Run Test”, labelled with the “Run Test” icon button as seen on the membrane. Press the button to modify the value of the manual "Run Test" duration.

Inside the lower box, the Automatic Shutdown may be activated and the duration of the “Run Period Timer” is shown. To edit the “Run Period Timer”, refer to the “Timers” page in the advanced configuration pages.

NumPad Page

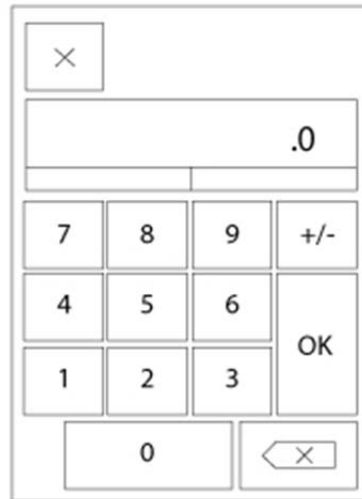

The NumPad is activated every time the user clicks on a white square box representing a number that can be set. On top of the NumPad, the current parameter is shown. The text will flash red if the value entered is invalid and the OK button will be black, indicating that the value is out of range. The MIN and MAX show the range of values accepted for that particular parameter. The “X” button allows the user to cancel editing the value. The back arrow erases the last entered number and the “CA” button clears the whole text field. Simply click the “OK” button once the value is set.

Date and Time Page

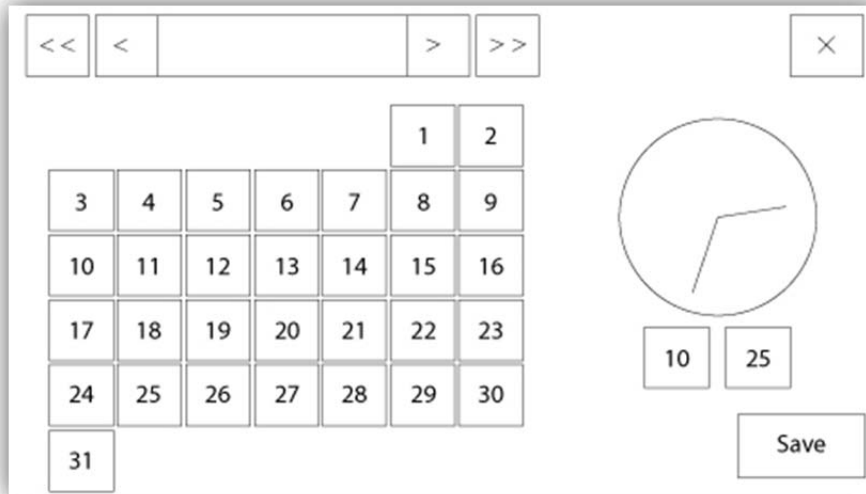

The interface for configuring the date and time. It features a calendar grid on the left and a clock on the right. The calendar grid shows days from 1 to 31. The clock shows the time set to 10:25. There are navigation buttons at the top and a 'Save' button at the bottom right.

| | | | | | | | | |
|----|----|----|----|----|----|----|---|--|
| << | < | | > | >> | | | × | |
| | | | | | | 1 | 2 | |
| 3 | 4 | 5 | 6 | 7 | 8 | 9 | | |
| 10 | 11 | 12 | 13 | 14 | 15 | 16 | | |
| 17 | 18 | 19 | 20 | 21 | 22 | 23 | | |
| 24 | 25 | 26 | 27 | 28 | 29 | 30 | | |
| 31 | | | | | | | | |

10 25

Save

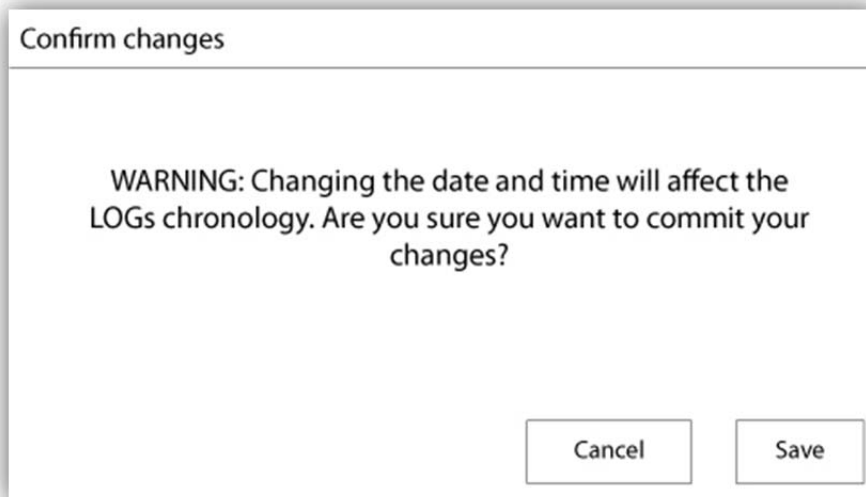

Confirm changes

WARNING: Changing the date and time will affect the LOGs chronology. Are you sure you want to commit your changes?

Cancel Save

The Date and Time can be configured by selecting the current month and year by pressing the arrow buttons on each side of the "Month-Year" display and selecting the day of the month by selecting the actual day. The time is set by pressing the two square boxes under the clock; the left sets the hours and the right sets the minutes. Press the Save button to commit the changes. A dialog box will appear to confirm the change "Date and Time". The user may cancel the changes by pressing the "Cancel" button. Please note that changing the date and time will have an effect on the logs chronology.

User Login Page / Keypad Page



User Login Keypad:

This page allows the user to log into a higher security level by entering a password. If the password is valid the text field will turn green and if it is invalid, the text field will turn red. A “X” button appears in the text field as soon as a character is entered, allowing for a quick erase of the written password.

If the password is invalid for a consecutive number of times, the user will be redirected to the “Service Dealer” page, allowing the user to communicate with the appropriate Service Dealer.

If the password is valid, the “Configuration” page will reload and the access security level will be shown inside the lock. To log off, click on the lock and the user security level will return to “0”

Other Keypads:

The Keypad is activated every time the user clicks on a grey rectangle box with white text representing a text that can be set. The “X” button allows the user to cancel editing the value. The back arrow erases the last entered character and the “CA” button clears the whole text field. Simply click the “OK” button once the value is set. This type of text field is mostly used to generate a digital text indication for a custom alarm input.

Advanced Configuration Page

Config > Advanced

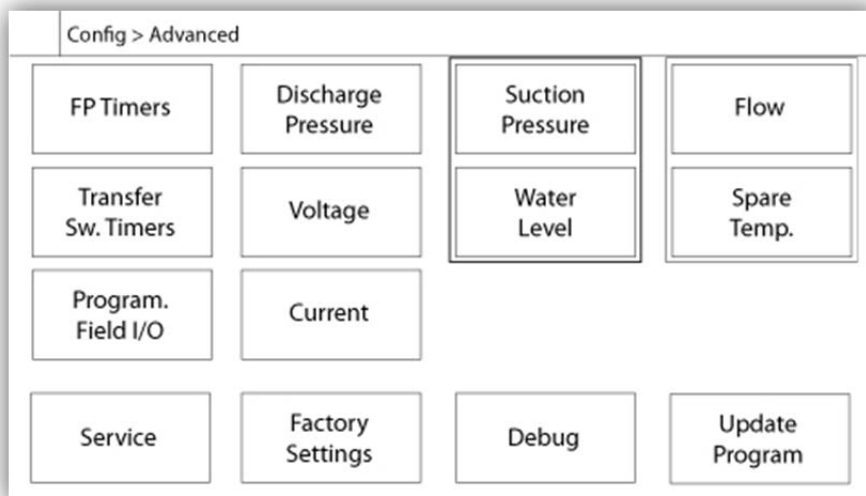

This page is the portal to all the advanced configuration parameters of the ViZiTouch.

All timers, sensors, factory settings, software update, service dealer and debug pages may be accessed simply by clicking on the appropriate buttons.

Since two of the analog inputs are using the same physical connector, only one of these can be installed at once. These analog inputs are shown in the grey box surrounded by a black dotted line. Each time one of these sensors is installed, the other will turn orange, preventing the dual installation of these sensors.

The Program Field I/O button appears only if an expansion board has been installed.

All buttons are set to security "Level 0" except "Update Program" which is set at "Level 1" security.

Details of the Advanced Configuration Page

Timers Page **Config > Advanced > FP Timers**

Config > Advanced > FP Timers

| | |
|--|--|
| Motor Starting and Stopping Sequential Start Timer <input type="text"/> s Run Period Timer <input type="text"/> m | Low Suction Pressure Alarm Timer On <input type="text"/> s |
| Starter Transition Timer <input type="text"/> s | Underpressure Timer On <input type="text"/> s |
| | Overpressure Timer On <input type="text"/> s |

Config > Advanced > FP Timers2

| | |
|---|---|
| Low Level Alarm Timer On <input type="text"/> s | High Level Alarm Timer On <input type="text"/> s |
| Low Spare Temperature Timer On <input type="text"/> s | Force Start on Flow Timer On <input type="text"/> s |

Most common timers can be configured here. Note that any timer set to 0 will remove the delay in the decision process.

Access level 1:

- Motor starting and stopping:
The sequential start timer set-point, in seconds, will delay an automatic motor starting.
The run period timer, in minutes, will delay the stopping of the motor when the automatic run cause of an automatic stop configured controller has returned to normal and that no other run causes are present.
- UnderPressure timer on: Time delay for the activation of underpressure alarm, if used.
- Overpressure timer on: Time delay for the activation of the overpressure alarm, if used.
- Low suction pressure alarm timer on: Time delay for the activation of the low suction pressure alarm, if used.
- Low Level Alarm timer on: Time delay for the activation of the low level alarm, if used.
- High level alarm timer on: Time delay for the activation of the high level alarm, if used.
- Low spare temperature: Time delay for the activation of the low spare temperature alarm, if used.
- Force start on flow: Time delay for the activation of the force start on flow alarm, if used.

Access level 2:

- Transition Timer: Will set the time for which a motor is in the temporary starting wiring configuration. When this timer expires, the motor will be wired in delta.

Timers Page

Config > Advanced > TS Timers

Config > Advanced > TS Timers

Transfer Switch Timers

Cooling Time m

Retransfer Time m

Most common timers for the transfer switch control can be configured here. Note that any timer set to 0 will remove the delay in the decision process.

Access level 1:

- Cooling Time: Time delay after which a running generator can be shut down when all running causes have return to normal.
- Retransfer time: Time delay used to re-qualify the normal power and retransfer. Typically five minutes.
-

Voltage Calibration

Config > Advanced > Voltage

| | | Actual (V) | Desired (V) | |
|-----------------------------|-------|----------------------|----------------------|---------|
| Normal Side Calib. | N1-N2 | <input type="text"/> | <input type="text"/> | COMPUTE |
| | N2-N3 | <input type="text"/> | <input type="text"/> | |
| | N3-N1 | <input type="text"/> | <input type="text"/> | |
| Alternate Side Calib. | E1-E2 | <input type="text"/> | <input type="text"/> | COMPUTE |
| | E2-E3 | <input type="text"/> | <input type="text"/> | |
| | E3-E1 | <input type="text"/> | <input type="text"/> | |

To calibrate the voltage sensing element of a power source, enter the 3 phase voltages as read on a calibrated meter then press compute. In the case of a transfer switch model, 3 additional voltages need to be calibrated the same way.

Current Calibration

Config > Advanced > Current

| | Actual (A) | Desired (A) | |
|----|----------------------|----------------------|--------------|
| I1 | <input type="text"/> | <input type="text"/> | ZERO COMPUTE |
| I2 | <input type="text"/> | <input type="text"/> | ZERO COMPUTE |
| I3 | <input type="text"/> | <input type="text"/> | ZERO COMPUTE |

To calibrate a particular current sensing element, enter the current value as read from a calibrated meter and then press compute. For best results, press the ZERO button when no current is flowing through the sensing element before calibrating.

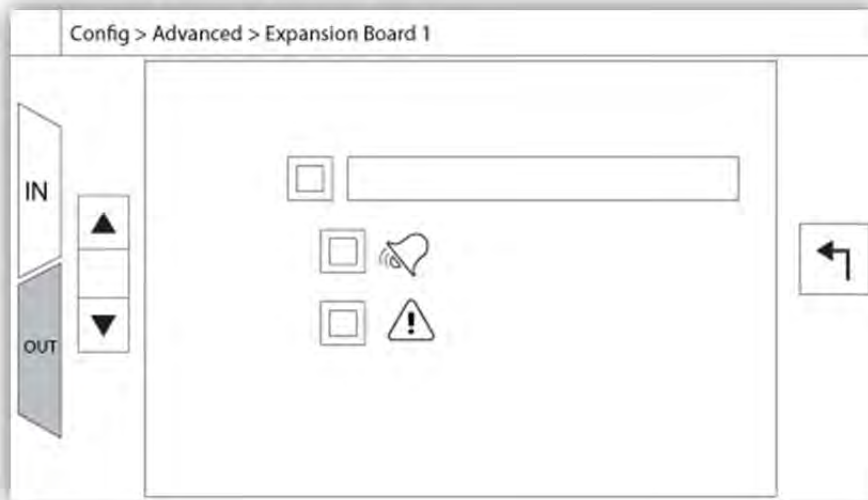
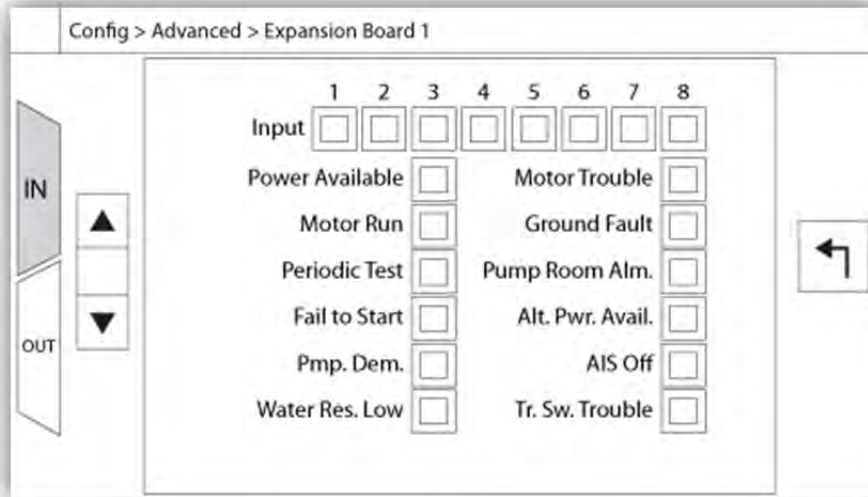

This page allows the configuration of both programmable inputs and outputs available on an IO Expansion board. Two buttons located far left swap between the input and output section of the page. Just beside, two square buttons labelled “+” and “-” are separated by a number that indicates the actual selected input/output. By using the “+ / -” buttons, it is possible to navigate between them easily.

Output:

The configuration is performed by pressing on the square box located beside one of the signal needed. The box will swap between BLANK (none), a NO (normally open) and a NC (normally close) symbol, allowing the desired configuration to be obtained. On top of all outputs signals available, it is possible to link in the same way the expansion board inputs to the selected output in any combination. The final state of the output signal is a logical “OR” combination of all selected signal.

Input:

The input page has three elements: the “Digital Text Indication” field, the “Alarm Bell Icon” and the “Alarm Icon”. Each one can be enabled or disabled. The first step is to click on the square button beside the text field to activate the management of the input signal. Then, clicking on the text field will bring up the KeyPad, making it easy to write a custom digital text indication. A maximum of 20 characters is allowed. Refer to the KeyPad help page for more information. If the “Alarm Bell Icon” is enabled, the input signal will trigger the Alarm Bell. If the “Alarm Icon” is enabled, the input signal will be treated as an alarm, if not, as a warning. As on the output page, the “+ / -” buttons allows for an easy navigation between all available inputs of the expansion board.

Update Program Page



This procedure is highly important and must be attempted with care. Please make sure to contact the factory prior to using the Update Software function.

To ensure the program update is successful:

- Make sure the USB Device is plugged in at all times during the procedure.
- Do not power off the ViZiTouch while updating the software.
- Make sure the procedure is complete before removing the USB device. The ViZiTouch will reboot automatically.

All active logs, data and configuration will not be affected by software updates. Usual operation of the controller will resume as soon as the software update is completed.

Factory Settings

Config > Advanced > Factory Settings

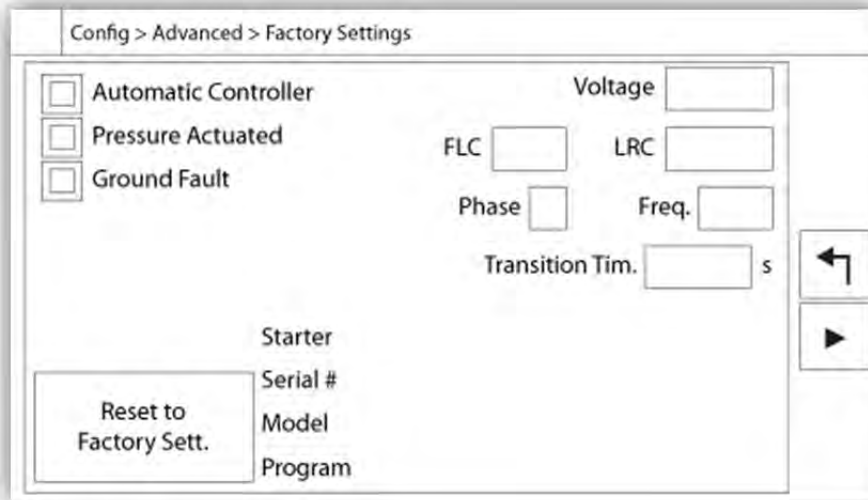

Config > Advanced > Factory Settings3

| | | | |
|-------------------------|---------------------------|----------------------|---|
| Calibrate Tch. Scrn. | High Zone Enable Delay | <input type="text"/> | s |
| | Low Zone Request Maintain | <input type="text"/> | s |
| | Soft Starter Bootup Time | <input type="text"/> | s |
| | LCD Dim Timer | <input type="text"/> | s |
| | LCD Off Timer | <input type="text"/> | s |
| | Low Ambient Temperature | <input type="text"/> | C |
| | High Ambient Temperature | <input type="text"/> | C |

Config > Advanced > Factory Settings2

| | | | |
|---|---|------------------------|---|
| <input type="radio"/> <input type="radio"/> <input type="radio"/> <input type="radio"/> | <input type="radio"/> <input type="radio"/> <input type="radio"/> <input type="radio"/> | Phase Loss | Fail to Start |
| <input type="radio"/> <input type="radio"/> <input type="radio"/> <input type="radio"/> | <input type="radio"/> <input type="radio"/> <input type="radio"/> <input type="radio"/> | <input type="text"/> % | <input type="text"/> % <input type="text"/> s |
| <input type="radio"/> <input type="radio"/> <input type="radio"/> <input type="radio"/> | <input type="radio"/> <input type="radio"/> <input type="radio"/> <input type="radio"/> | Phase Unbal. | Ground Fault |
| <input type="radio"/> <input type="radio"/> <input type="radio"/> <input type="radio"/> | <input type="radio"/> <input type="radio"/> <input type="radio"/> <input type="radio"/> | <input type="text"/> % | <input type="text"/> % <input type="text"/> s |
| <input type="radio"/> <input type="radio"/> <input type="radio"/> <input type="radio"/> | <input type="radio"/> <input type="radio"/> <input type="radio"/> <input type="radio"/> | Oversvoltage | Overcurrent |
| <input type="radio"/> <input type="radio"/> <input type="radio"/> <input type="radio"/> | <input type="radio"/> <input type="radio"/> <input type="radio"/> <input type="radio"/> | <input type="text"/> % | <input type="text"/> % <input type="text"/> s |
| <input type="radio"/> <input type="radio"/> <input type="radio"/> <input type="radio"/> | <input type="radio"/> <input type="radio"/> <input type="radio"/> <input type="radio"/> | Undervoltage | Undercurrent |
| <input type="radio"/> <input type="radio"/> <input type="radio"/> <input type="radio"/> | <input type="radio"/> <input type="radio"/> <input type="radio"/> <input type="radio"/> | <input type="text"/> % | <input type="text"/> % <input type="text"/> s |

The factory settings are always pre-configured at the factory and set the main parameters of the controller. Most of the settings found on this page can only be changed by an authorized Tornatech employee and is protected by a level 8 password.

Automatic Controller – Non-Automatic Controller: An automatic controller will respond to automatic start requests, like a pressure transducer, a pressure switch, a deluge valve or a remote automatic start trigger. A non-automatic controller will only start the motor on manual requests.

Pressure Actuated – Non-Pressure Actuated: A pressure actuated controller has at least one pressure transducer installed and will monitor the system pressure at all time. In an automatic controller, the pressure drop will start the motor.

Enable/Disable – Ground Fault: The “Ground Fault” is a factory installed option that will enable or disable the Ground Fault Visual Indication.

“Reset to Factory Settings”: This button redirects to the “Reset to Factory Settings” page. This is a major operation that must be used with care and only if the factory was contacted first. See the “Reset to Factory Settings” help for more details.

Voltage: Nominal voltage of the controller

FLC: Full load current rating of the motor.

LRC: Lock rotor current rating of the motor. Unless specified, this value is automatically set to six times the FLC.

Phase: Input power number of phases.

Frequency: Input power frequency.

Transition Timer: Will set the time for which a motor is in the temporary starting wiring configuration. When this timer expires, the motor will be wired in delta.

Starter: Motor starter configuration. This value is read-only.

Serial: Serial number of the controller. This value is read-only.

Model: Model number of the controller. This value is read-only.

Program: Program version of the ViZiTouch. This value is read-only.

Phase Loss: Sets the value in percentage of the nominal voltage. If a phase voltage reading is lower, the corresponding alarm/warning will be activated.

Phase Unbalanced: Sets the value in percentage of the nominal voltage. If the difference between two phase voltage readings is more than this gap percentage, the alarm/warning will be activated.

Overvoltage: Sets the value in percentage of the nominal voltage. If a phase voltage reading is higher, the alarm/warning will be activated.

Undervoltage: Sets the value in percentage of the nominal voltage. If a phase voltage reading is lower, the alarm/warning will be activated.

Fail to Start: Sets the value in percentage of the motor's Full Load Current (FLA) and its associated delay. If the motor should be running and the current reading is lower than this percentage of the FLA, the alarm/warning will be activated at the end of the programmed delay in seconds.

Ground Fault: Sets the value in Amperes and its associated delay. If the Ground Fault Current reading is higher than this value, the alarm/warning will be activated at the end of the programmed timer.

Overcurrent: Sets the value in percentage of the motor's Full Load Current (FLA) and its associated delay. If the average current reading is higher than this percentage of the FLA, the alarm/warning will be Activated.

Undercurrent: Sets the value in percentage of the motor's Full Load Current (FLA) and its associated delay. If the average current reading is lower than this percentage of the FLA while the motor is running, the alarm/warning will be Activated.

Higher Zone Enable Delay: Delay, in seconds, after which a motor run signal is sent to a higher zone controller. This option is only used for controllers in series.

Lower zone Request Maintain: Delay, in seconds, for which a run demand to a lower zone controller is maintained after all run causes has return to normal. This option is only used for controllers in series.

Soft Starter Bootup Time: Time delay given to the solid state starter after a controller powers on before monitoring its fault signal.

LCD Backlight Dim Timer: The inactivity time it takes for the ViZiTouch screen to start fading out. This is done to preserve the durability of the screen's backlight. It is factory programmed to 5 minutes.

LCD Backlight Turn Off Timer: The inactivity time it takes for the ViZiTouch screen to turn off completely. It is factory programmed to 5 minutes.

The inactivity timer starts if no "user actions" are detected on the screen or the membrane, the engine is not running

and no alarms are “ACTIVE”. As soon as one of those conditions is met, the inactivity timer will reset.

Low Ambient Temperature: Set-point for the low ambient temperature alarm.

High Ambient Temperature: Set-point for the high ambient temperature alarm.

Calibrate touch screen: This button can be used to recalibrate the touch screen of the ViZiTouch in case of a non-accurate response.

Factory Settings

Config > Advanced > TS Factory Settings

Config > Advanced > TS Factory Settings

| | |
|---|--|
| Normal Dropout Voltage <input type="text"/> % | Normal Outage <input type="text"/> s |
| Normal Pickup Voltage <input type="text"/> % | Normal Available Delay <input type="text"/> s |
| Alternate Dropout Voltage <input type="text"/> % | Transfer Trouble Time <input type="text"/> s |
| Alternate Pickup Voltage <input type="text"/> % | Dropout Frequency <input type="text"/> % |
| Phase Differential <input type="text"/> % | Pickup Frequency <input type="text"/> % |

Config > Advanced > TS Factory Settings 2

Load Shedding

Permanent Load Shedding

Temporary Load Shed. 1 s

Temporary Load Shed. 2 s

Motor Run Delay
 s

The factory settings are always pre-configured at the factory and set the main parameters of the controller. Most of the settings found on this page can only be changed by an authorized Tornatech employee and is protected by a level 8 password.

Normal dropout voltage: Percentage of nominal voltage under which the normal power source will be disqualified (after expiration of the normal outage delay).

Normal pickup voltage: Percentage of nominal voltage above which the normal power source will be re-qualified (after expiration of the retransfer time).

Normal outage: Delay after which the normal power can be disqualified.

Alternate dropout voltage: Percentage of nominal voltage under which the alternate power source will be disqualified.

Alternate pickup voltage: Percentage of alternate voltage above which the normal power source will be qualified (after expiration of the alternate available delay).

Alternate available delay: Delay after which the alternate power source can be qualified.

Transfer trouble time: Delay after which un-activated normal and alternate position limit switches will trigger a transfer switch trouble alarm.

Phase differential: Percentage of nominal voltage above which phase differences on the normal power source will cause a phase unbalanced alarm.

Dropout frequency: Percentage of nominal frequency under which a power source can be disqualified.

Pickup frequency: Percentage of nominal frequency above which a power source can be re-qualified.

Load shedding: This section will enable load shedding configuration, provided that the option was ordered.

Permanent load shedding: Use the permanent load shedding output

Temporary load shedding 1: Use the temporary load shedding output 1. Individual delay can be set for this output.

Temporary load shedding 2: Use the temporary load shedding output 2. Individual delay can be set for this output.

Motor run delay: Time by which the motor starting is delayed for load shedding purposes.

Reset to Factory Settings Page

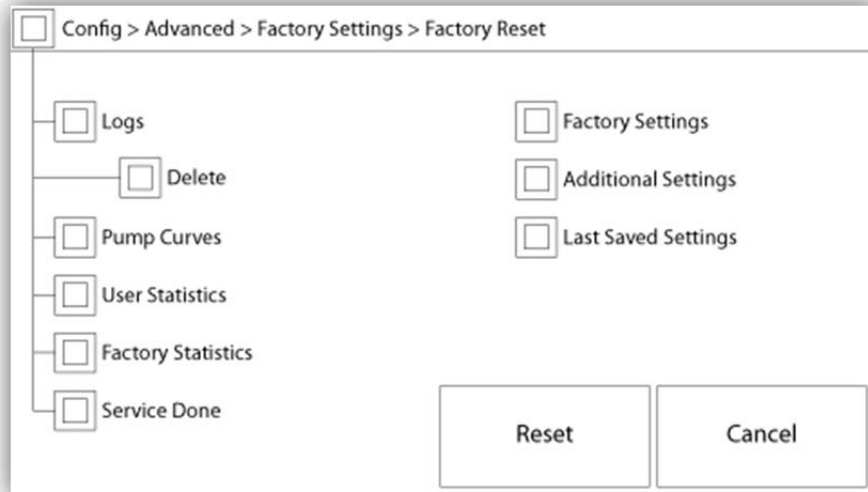

This page will reset the ViZiTouch to the original factory configuration, thus clearing all subsequent configurations performed during the life of the controller.

This procedure should only be used as a last attempt to bring back the controller to a usable state.

User "Level 2":

The "RESET" button will be activated (will become blue) only if no square buttons from the left column are activated and the "Last Saved Settings" from the right column is not activated as well. A "Level 2" user can only reset the "Factory Settings" and/or the "Additional Settings" from the right column.

The “Factory Settings” reset will restore the controller to its original factory configuration and service state. This means that the first service will be undone, automatic mode settings, as well as the controller’s “Homepage” will be deactivated until “First Service” is completed again. Please refer to the “Quick Start-Up” guide for more information on how to perform the “First Start-Up” and how to complete the “Field Acceptance Test Report”.

Please note that all logs, pump curves and statistics will not be reset.

The “Additional Settings” reset will update the controller with an additional configuration sent by the manufacturer. It does not perform a true “Factory Reset”. Its purpose is to allow an update of configuration variables that can only be updated by Tornatech Inc.

All other square buttons on this page are “Level 9” security and can only be used by certified Tornatech representatives, unless otherwise specified. The first square in the upper left corner performs the “Select all” function for these parameters.

Service Page

Config > Advanced > Service

The screenshot shows a web interface titled "Config > Advanced > Service". It features a large square button in the top-left corner. To its right is a section for "Company Name" with a text input field. Below this are fields for "Contact Name", "Phone number #1", "Phone number #2", and "email address". To the right of the company name section is a "Last Pump Curve" section with a "NEW" button. At the bottom, there is a "Service Done" button, a "Last Done:" label, a plus sign, a text input field, an equals sign, a "Next On:" label, and a back arrow button.

The upper left section hosts the Tornatech Inc. business card by default. This image can be changed by the service dealer to incorporate a customized image. The image must have been created by Tornatech Inc., sent to the service dealer and copied on a USB Device. The “Level 1” user can update the image by pressing the Tornatech logo when the USB Device containing the business card is inserted into the USB port. Please contact factory for more details.

The box situated just right of the business card is related to the “Pump Curve”. The ViZiTouch allows the for recording of up to 10 different pump curves. The date and time of the last pump curve recorded is displayed here. The “NEW” button allows the user to record a new pump curve. Clicking this button will redirect the user to the “New Pump Curve” page. See the “New Pump Curve” help section for more details on how to record a new pump curve.

The user can see both the date of the last service done and the date of the next service at the bottom of the screen.

Access level 1:

- Change the period before the next service is required by pressing the white box between the “Last Done” date and the “Next On” date. The “Next On” date will be adjusted automatically depending on the period selected and the date of the last service.

When the required service is done, the user must click on the “Service Done” button to commit and end the service.

| | Pdis | - | Psuc | = | Pnet | Flow | Volt | Current |
|---|------|---|------|---|------|------|------|---------|
| 1 | | | | | | | | |
| 2 | | | | | | | | |
| 3 | | | | | | | | |
| 4 | | | | | | | | |
| 5 | | | | | | | | |

Buttons: Reset, Auto, Save, Back Arrow

The Service Dealer “New Pump Curve” Procedure

This page allows the user to create a pump curve. At the bottom of the screen, there are 3 buttons:

- Reset: Clears the data of the pump curve in progress.
- Auto: Uses needed types of transducers to create the pump curve (Discharge pressure, Suction pressure and Flow sensor need to be installed.)
- Save: Saves the pump curve and update the pump curve chronological order as displayed in the “History > Pump Curves” page.

The first line of the legend displays the system units for every column. The second row of the legend describes the parameters represented and the third line of the legend displays the actual value of these parameters for quick reference. The scroll bar on the right of the table allows the user to move downward in the table, up to the 10th point. The new pump curve data will become invalid if the Flow or Pressure units are changed during the input procedure or if no Flow or Pressure data is entered. In that case, click on the reset button. The Save button must be used in order to record the pump curve into the ViZiTouch memory.

- Pdis: Discharge Pressure
- Psuc: Suction Pressure
- Pnet: The Net Pressure is calculated by subtracting the Suction Pressure from the Discharge Pressure. In Manual Mode, it must be entered manually.
- Flow: Flow
- Volt: Voltage of the pump
- Current: Current of the pump

“Manual Mode”

To manually create a pump curve, data must first be entered on the first row and then on subsequent rows. There are a total of 10 rows available, but there is no minimum required to get a curve. Of course, more rows improve precision.

In each column the user must input every following value for maximum information, readability and future reference. It is possible to create a quick pump curve, but it is not recommended since future references might be less accurate. In that case, only fill the Pnet and the Flow values. The first row of data must set the “Flow” to 0 and the last row of data must have a Pnet of 0. These values will ensure the pump curve is fully represented on the graph, for all pressure and all flows.

When the required number of points are entered, just click on the “Save” button to record the pump curve and exit this page. You will be redirected to the “History > Pump Curve” page.

“Auto Mode”

To automatically create a pump curve, the discharge pressure, suction pressure and flow meter must all be installed on the controller.

-Click on the “Auto” button

-A series of validation will take place to ensure all data is valid.

-After a pre-defined timer, the ViZiTouch will acquire all data from all sensors and fill the first row of the pump curve table. The pressure must be stabilized before the samples are to be taken. The Pnet pressure will be calculated.

-The ViZiTouch will then ring the Alarm Bell shortly, alerting the user to drop the pressure. As soon as the pressure is stabilized once again, the ViZiTouch will take the second row of values.

-This automatic procedure will go on until the discharge pressure is near zero.

-The ViZiTouch will then take the last row of samples and stop the Automatic mode acquisition.

-At any point, it is possible to reset the recorded values and start the automatic mode sequence from the beginning.

- Click on the “Save” button to record the pump curve and exit this page. The user will be redirected to the “History > Pump Curve” page.

Automatic Pump Curve Mode Disabled

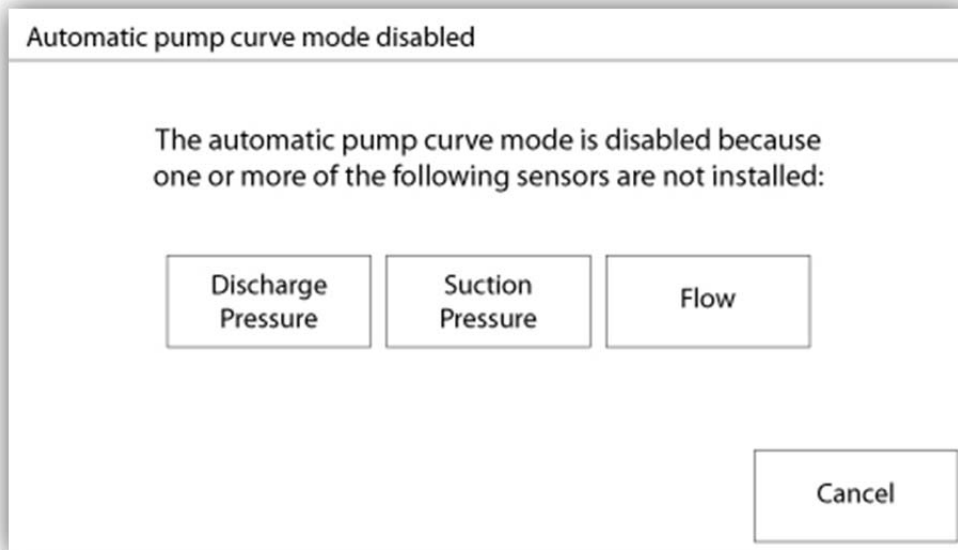

The automatic pump curve was disabled because it needs three sensors installed. The three sensors buttons link to the corresponding sensor page, allowing a quick navigation. If the button is orange, this indicates that this particular sensor is not installed. If the button is blue, it means that this particular sensor is installed. It is always possible to quit the automatic mode by pressing the "Cancel" button.

The Sensors Pages

Config > Advanced > Discharge Pressure

| Sensor | Alarms |
|--|---|
| <input type="text" value="PT1"/> | <input type="checkbox"/> Over Pressure |
| Calib. <input type="text"/> | <input type="checkbox"/> SET <input type="text"/> |
| Range <input type="text"/> <input type="text"/> <input type="button" value="Apply"/> | <input type="checkbox"/> RESET <input type="text"/> |
| | <input type="checkbox"/> Under Pressure |
| | <input type="checkbox"/> SET <input type="text"/> |
| | <input type="checkbox"/> RESET <input type="text"/> |

Calibration

<

Config > Advanced > Suction Pressure

| Sensor | Alarms |
|--|---|
| <input type="checkbox"/> Installed | <input type="checkbox"/> Low Suction Pressure |
| Calib. <input type="text"/> | <input type="checkbox"/> SET <input type="text"/> |
| Range <input type="text"/> <input type="text"/> <input type="button" value="Apply"/> | <input type="checkbox"/> RESET <input type="text"/> |

Calibration

<

Config > Advanced > Water Level

| Sensor | Alarms |
|--|--|
| <input type="checkbox"/> Installed | <input type="checkbox"/> High Water Level |
| Calib. <input type="text"/> | <input type="checkbox"/> SET <input type="text"/> DRY <input type="checkbox"/> |
| Range <input type="text"/> <input type="text"/> <input type="button" value="Apply"/> | <input type="checkbox"/> RESET <input type="text"/> |
| | <input type="checkbox"/> Water Reservoir Low |
| | <input type="checkbox"/> SET <input type="text"/> DRY <input type="checkbox"/> |
| | <input type="checkbox"/> RESET <input type="text"/> |

Calibration

<

Config > Advanced > Flow

| Sensor | Alarms |
|--|---|
| <input type="checkbox"/> Installed <input type="text"/> Calib. <input type="text"/> Range <input type="text"/> <input type="text"/> <input type="button" value="Apply"/> | <input type="checkbox"/> Force Start on Flow <input type="checkbox"/> SET <input type="text"/> DRY <input type="checkbox"/> RESET <input type="text"/> <input type="checkbox"/> |
| Calibration <input type="text"/> <input type="button" value="Read"/> < <input type="text"/> <input type="button" value="Read"/> <input type="button" value="COMPUTE"/> <input type="button" value="↩"/> | |

Config > Advanced > Spare Temperature

| Sensor | Alarms |
|--|--|
| <input type="checkbox"/> Installed <input type="text"/> Calib. <input type="text"/> Range <input type="text"/> <input type="text"/> <input type="button" value="Apply"/> | <input type="checkbox"/> Low Spare Temp. <input type="checkbox"/> SET <input type="text"/> <input type="checkbox"/> RESET <input type="text"/> |
| Calibration <input type="text"/> <input type="button" value="Read"/> < <input type="text"/> <input type="button" value="Read"/> <input type="button" value="COMPUTE"/> <input type="button" value="↩"/> | |

In the ViZiTouch, all sensors refer to analog input connectors on the I/O board. They all have similar settings and configuration.

The “Installed” selection (“Level 2” security): Install or uninstall this sensor from the ViZiTouch configuration.

Discharge Pressure: To set the pressure system unit, go the “Config” page. All pressure transducers share the same unit.

The “Source” button (4 choices): (“Level 2” security)

- None: No pressure transducer or pressure switch is installed
- PT1 (factory standard): Only the AI1-PT1 terminal on the “T” terminal strip is enabled.
- PT2: Only the AI2-PT2 terminal on the “T” terminal strip is enabled.
- AUTO (factory installed option): AI1-PT1 and AI2-PT2 are installed and arranged for a redundancy system. The ViZiTouch will always consider the lowest of the two pressure values as the reference. Additional alarms, like “PT fault detected” become enabled. This alarm is triggered when the two transducers provides values that are different by more than a pre-set delta value. The ViZiTouch will never make a decision as to which transducer is faulty; it will only reveal that there is a problem with one of them. The service dealer should test both transducers to find out which one is faulty.

Suction Pressure: To set the pressure system unit, go the “Config” page. All pressure transducers share the same unit.

The “suction pressure” sensor shares the same analog input (AI4-W-S) as the water level sensor. Only one of them can be installed at all time. Prior to installing one of them, the other one must be uninstalled by visiting its own sensor page.

Flow: The "Flow" sensor shares the same analog input (AI3-Q-T) as the spare temperature sensor. Only one of them can be installed at all time. Prior to installing one of them, the other one must be uninstalled by visiting its own sensor page.

The "Unit" button is located just right of the "Installed" selection. Click on it to select the appropriate "Flow" Unit, the factory pre-set unit is the GPM.

Flow Start:

- Enable/Disable the "Flow Start" condition by pressing the square button. If this alarm is enabled, it will also start the engine by means of a "FLOW" request.
- Alarm Bell Icon: Activates the bell when a "Flow Start" occurs.
- Alarm Icon: If selected, the "Flow Start" event will be an alarm. If unselected, it will be a warning.
- Value: Flow value at which the "Flow Start" event will change state.
- Timer On: Timer used to buffer the activation of the "Flow Start" signal by the ViZiTouch.

Water Level: The "Water Level" sensor shares the same analog input (AI4-W-S) as the suction pressure sensor. Only one of them can be installed at all time. Prior to installing one of them, the other one must be uninstalled by visiting its own sensor page. The "Water Level" sensor has no unit, since it is monitoring the "Water Level" as a percentage.

Spare Temperature: The "Spare Temperature" sensor shares the same analog input (AI3-Q-T) as the Flow sensor. Only one of them can be installed at all time. Prior to installing one of them, the other one must be uninstalled by visiting its own sensor page. The "Unit" button is located just right of the "Installed" selection. Click on it to select the appropriate "Spare Temperature" Unit, the factory pre-set unit is the Celsius.

Fuel Level (GPD Model Only): The "Fuel Level" sensor has no unit, since it is monitoring the "Fuel Level" as a percentage.

The Calibration method is the same for all sensors.

CALIBRATION:

The Calibration button: ("Level 2" security for the choice of calibration, but "Level 1" security for the calibration procedure itself.) There are 4 ways to calibrate every sensor:

- 0-10V: Theoretical calibration with 0-10V sensor. Simply enter a value in the system pressure unit for 0V and another value for 10V. Click on the "Apply" button to confirm the calibration. The resulting measured pressure is shown in the lower right corner of the "Sensor" box. Make sure the dipswitch package right below the "T" terminals is set to "0-10V" for that particular sensor (refer to the drawing). The switches are labelled and are each linked to one analog input, in this case "1 or 2". *Important Note: A set of jumpers is also associated with each analog input. MAKE SURE THE CONTROLLER IS COMPLETELY POWERED OFF BEFORE MOVING A JUMPER. THIS INCLUDES REMOVING THE AC AND DC POWER. The jumper can be placed on "5Vdc", "12Vdc" and "Vaux" and represents the powered DC value of the sensor. The factory pre-set position is "5Vdc". If an installed sensor has a power value of "5Vdc", then the "0-10V" theoretical calibration must be calculated accordingly. Please contact manufacturer for more information.

- 4-20mA: Theoretical calibration with 4-20mA sensor. Simply enter a value in the system pressure unit for 4mA and another value for 20mA. The procedure explained above also applies in this case.

-Field Calibration: This is the factory pre-set method and the only one that is an actual calibration. Selecting this calibration method will generate the Calibration box situated in the lowest part of the sensor page. It is very important that the same care is used when selecting the appropriate dipswitch setting and jumper position. Please refer to the "0-10V" section above.

1. Two actual points (low and high) are required
2. Set the lowest point (usually 0).
3. Press the left read button
4. Press the left rectangle text field and enter the value read on the external calibrated gauge.
5. Set a high point (usually the highest possible value will create the best calibration).
6. Press the right read button
7. Press the right rectangle text field and enter the value read on the external calibrated gauge.

8. Press the calculate button to finish the calibration. If the settings are incorrect, the calculate button will remain red and if correct, the button will turn blue. The resulting measured value is shown in the lower right corner of the "Sensor" box.

- On/Off: Use the input with a dry contact sensor, for example a float switch. The only parameter to set for this method is the NO/NC buttons, effectively selecting between a normally open and a normally close switch. Click on the "Apply" button to confirm the calibration.

The Alarms Section: ("Level 1" security)

The "DRY" button can enable or disable the "Dry Contact Input" on the IO board. There are two modes when enabled, either "Normally open, NO" or "Normally close, NC". Each mode is represented by the standard NO/NC symbols.

- Enable/Disable the corresponding alarm/warning condition by pressing the square button
- Alarm Bell Icon: Activates the bell when the condition occurs.
- Alarm Icon: If selected, the occurring condition will be an alarm. If unselected, it will be a simple warning.
- RESET: Value at which the condition will go from the "ACTIVE" state to the "OCCURRED" state.
- SET: Value at which the system will activate the corresponding condition.

Details of the Debug Page

Calibration

Config > Advanced > Debug > Calibration

Config > Advanced > Debug > FP Calib.

Scaled = Raw * Gain + Offset

| |
|----------|
| L12 |
| L23 |
| L31 |
| I1 |
| I2 |
| I3 |
| Igf |
| PT1 |
| PT2 |
| SucPress |
| WatLev |
| Spare T. |
| Flow |



Config > Advanced > Debug > TS Calibration

Scaled = Raw * Gain + Offset

| |
|-----|
| N12 |
| N23 |
| N31 |
| E12 |
| E23 |
| E31 |



This table displays all calibration parameters. The “Scaled” value is the final calculated value used in the ViZiTouch. It is calculated by multiplying the “Raw” value by the “Gain” coefficient and by adding the “Offset” value. This information is useful when debugging the analog inputs on the IO board.

IO Debug

Config > Advanced > Debug > IO

Config > Advanced > Debug > IO FP

| | | | | |
|--------------------|-----------------------|------------------|-----------------------|------|
| Emergency LS | <input type="radio"/> | CR4 | <input type="radio"/> | TEST |
| Factory Reserved 4 | <input type="radio"/> | CR5 | <input type="radio"/> | TEST |
| Remote Manual | <input type="radio"/> | Power Available | <input type="radio"/> | TEST |
| Remote Automatic | <input type="radio"/> | Field Prog. Out. | <input type="radio"/> | TEST |
| Deluge Valve | <input type="radio"/> | Phase Reversal | <input type="radio"/> | TEST |
| Factory Reserved 3 | <input type="radio"/> | WT SV | <input type="radio"/> | TEST |
| Flow | <input type="radio"/> | Shunt Trip | <input type="radio"/> | TEST |
| Factory Reserved 2 | <input type="radio"/> | Motor Trouble | <input type="radio"/> | TEST |
| Factory Reserved 1 | <input type="radio"/> | Pump Room Alarm | <input type="radio"/> | TEST |

Config > Advanced > Debug > IO TS

| | | | | |
|--------------------------|-----------------------|------------------|-----------------------|------|
| Alternate CB Tripped/Off | <input type="radio"/> | Controller Ready | <input type="radio"/> | TEST |
| Alternate IS Tripped/Off | <input type="radio"/> | Transfer | <input type="radio"/> | TEST |
| Normal Position | <input type="radio"/> | Genset | <input type="radio"/> | TEST |
| Alternate Position | <input type="radio"/> | Shunt Trip | <input type="radio"/> | TEST |

The small white circle beside each signal is a representation of its state. If the white circle is filled with a green dot, then the signal is activated. Comparing these software signals and the physical state of the signal on the electronic board is the best way to troubleshoot. In the right column, additional “TEST” buttons are located beside each output signal. Clicking on these buttons will toggle the output state of this signal, again allowing a comparison between the software and hardware state of these signals to help troubleshoot.

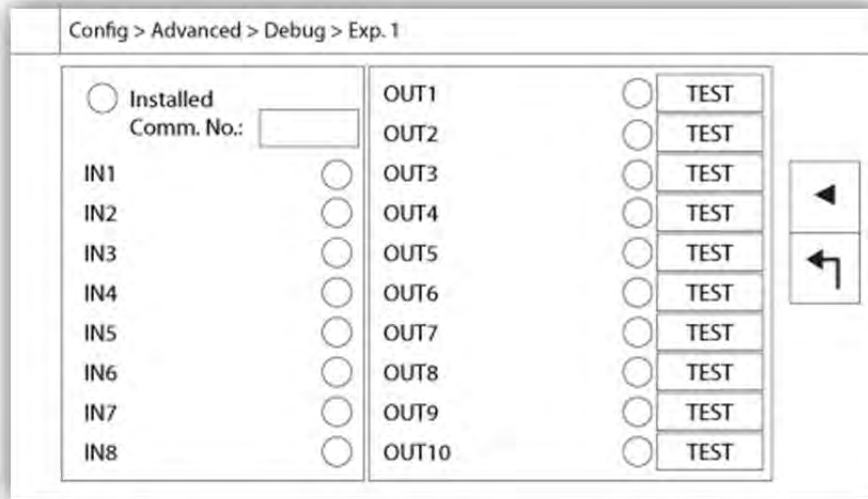

The small white circle beside each signal is a representation of its state. If the white circle is filled with a green dot, then the signal is activated. The first element in the left column is the indication of whether or not the optional Expansion board is installed. In the box, the corresponding Expansion board number is displayed. Comparing between these software signals and the physical state of the signal on the electronic board is the best way to troubleshoot. In the right column, additional "TEST" buttons are located beside each output signal. Clicking on these buttons will toggle the output state of this signal, again allowing a comparison between the software and hardware state of these signals to help troubleshoot.

History



History (Membrane button)

History

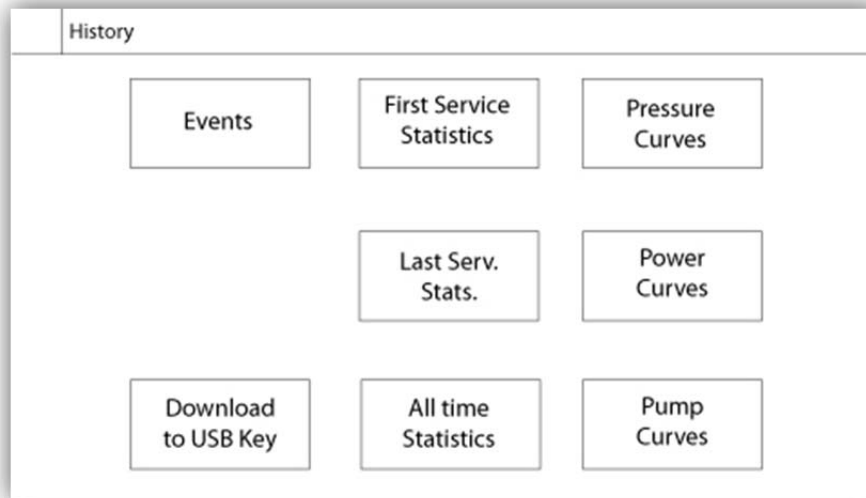

Select specific pages within the history section. Everything related to the statistics, events, pressure, power logs and the download to USB is available within the History page.

-Events: This button leads to the “Events” page, which displays the most recent 500 events. Each event log contains the date and time of occurrence as well as a brief description of the event.

-Download to USB Device: This button leads to the “Download to USB Device” page, which allows the user to download information, including the user manual, drawings, logs, statistics and configuration.

-First Service Statistics: This button leads to the “First Service Statistics” page, which displays all relevant statistics calculated since the very first service done on the controller.

-Last Service Statistics: This button leads to the “Last Service Statistics” page, which displays all relevant statistics calculated since the last service done on the controller.

-All Time Statistics: This button leads to the “All Time Statistics” page, which displays the date and time of the first power up, the date and time when the first start-up was completed and the total “On Time” of the controller. These statistics can never be reset.

-Pressure/Power Curves: This button leads to the “Pressure Curves” / “Power Curves” page accordingly, which displays all relevant pressure/power information.

-Pump Curves: This button leads to the “Pump Curves” page.

Details of the History Page

Events Page

History > Events Log

| | Date | Time | Message |
|----|------|------|---------|
| 1 | | | |
| 2 | | | |
| 3 | | | |
| 4 | | | |
| 5 | | | |
| 6 | | | |
| 7 | | | |
| 8 | | | |
| 9 | | | |
| 10 | | | |

A contextual navigation pad icon is located in the bottom right corner of the table area.

It shows the last 500 events which occurred in chronological order. The first column is the date, the second one is the time of occurrence and the third column is the “Event message”. To obtain a log that is older than 500 events, visit the “Download to USB Device” page and select “Events”. This method will generate a file containing all events logs in the ViZiTouch history.

The contextual navigation pad is implemented in this page. It allows quick navigations functions, like “previous page”, “next page”, “first page” and “last page”. As always, clicking on the Navigation Pad Icon in the lower right corner of the screen will pop-up the Navigation Pad functions specific for this page.

Download to USB Device

History > Download to USB

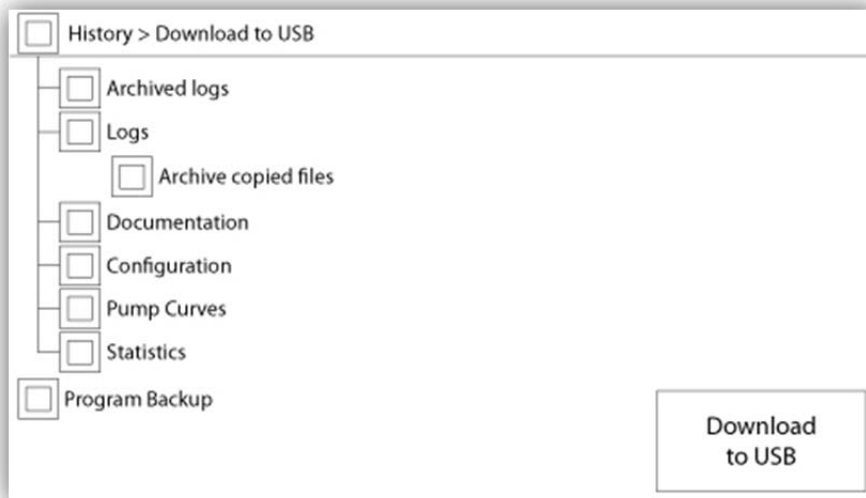



To download information from the ViZiTouch to a USB Device a user with at least a “level 1” password must be logged in. The first square beside the title is a “Select All” button. Pressing it will select all categories except “Archive copied files”, which serves a separate purpose. The entire right side is filled with different progress bars, to help monitor the current transfer. The “Download to USB” button will execute the command. If a USB Device is not present or if there is an error, a message saying “Could not mount USB drive” will appear and any further action is cancelled. To try again, remove the device, re-insert and press the button once more.

-Archived logs: All logs files that were archived using the “Archive copied files” square button. The purpose of archiving files is to free up memory on the ViZiTouch by archiving older log files.

-Logs: All logs are currently available in the ViZiTouch memory. A “Comma Separated Values” or “.csv” file is created every day and is named accordingly. Most software in modern computers will be able to read and interpret these files. The log files contain the event logs, the pressure logs and the power logs.

-Documentation: All “.pdf” files available in the ViZiTouch, usually the complete user manual, the quick startup guide, the drawings and schematics.

-Configuration: All configuration parameters contained in a “.txt” file, including but not limited to nominal values, serial number, calibration parameters.

-Pump Curves: A “Comma Separated Values” or “.csv” file is created for every pump curve created and is named accordingly. Every column is clearly identified with a title describing the values.

-Statistics: A “.csv” file including every kind of statistics, minimum, maximum, average for pressure and temperature and all engine statistics, as well as factory data.

Program Backup: A compressed and encrypted file, only readable by the ViZiTouch. This allows the user to copy a complete ViZiTouch to another one. **IMPORTANT:** The ViZiTouch is not in service while downloading the program backup.

The Statistics

First/Last Service Statistics History > Statistics since first/last service

| History > Statistics since first service | |
|--|--------------------|
| Since | On Time |
| <hr/> | |
| Motor | Generator |
| Last Run | Last Run |
| Run Time | Run Time |
| Start Count | Transfer Count |
| Pressure | Temperature |
| Minimum | Minimum |
| Maximum | Maximum |
| Average | Average |

| History > Statistics since last service | |
|---|--------------------|
| Since | On Time |
| <hr/> | |
| Motor | Generator |
| Last Run | Last Run |
| Run Time | Run Time |
| Start Count | Transfer Count |
| Pressure | Temperature |
| Minimum | Minimum |
| Maximum | Maximum |
| Average | Average |

The following description applies to two pages, reachable by the “First Service Statistics” and the “Last Service Statistics” button on the History page. All statistics shown here are calculated since the first/last service was done. All dates are in the YYYY.MM.DD format and all time references are in the HH:MM:SS format.

- Since: Date and time when the first/last service was done.
- On Time: Total duration of controller powered on during that period.

Motor:

- Last run: Date and time of the motor's last run.
- Run time: Total running time of the motor during that period.
- Start count: Number of times the motor started during that period.

Pressure:

- Minimum: Value of minimum pressure displayed in the system actual unit and the moment it was reached.
- Maximum: Value of maximum pressure displayed in the system actual unit and the moment it was reached.
- Average: Calculated value of the average pressure during that period displayed in the system actual unit.

Temperature:

- Minimum: Value of minimum temperature displayed in the system actual unit and the moment it was reached.

- Maximum: Value of maximum temperature displayed in the system actual unit and the moment it was reached.
- Average: Calculated value of the average temperature during that period displayed in the system actual unit.
- Generator(for transfer switch models only):
- Last Run: Date and time of the generator/second utility last run.
- Run time: Total running time of the generator/second utility during that period.
- Transfer Count: Number of times the power was transferred to the alternate side during that period.

All Time Statistics

History > All Time Statistics

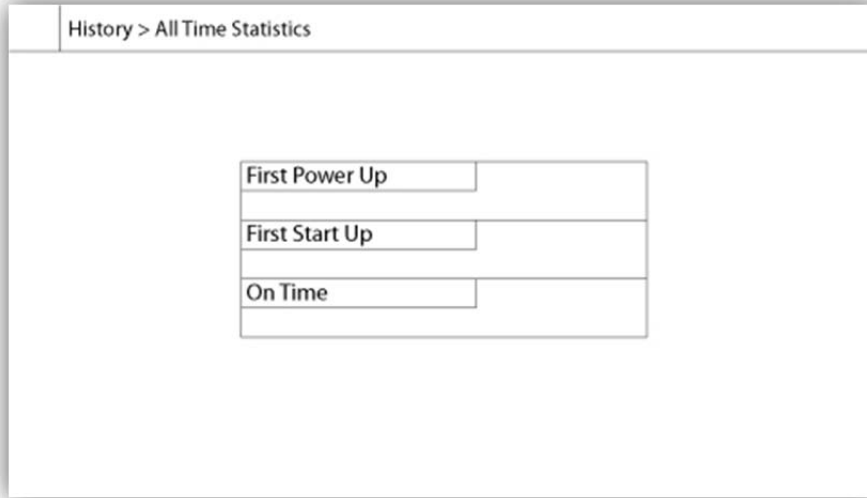

All statistics shown here are calculated since the controller's first start-up was done. All dates are in the YYYY.MM.DD format and all time references are in the HH:MM:SS format.

- First Power Up: Date and time of when the controller was first powered up.
- First Start Up: Date and time of when the controller's first start-up was completed.
- On Time: Total duration of controller powered on since the first power-up.

Pressure Curves

Graphical Mode

History > Pressure Log Curves

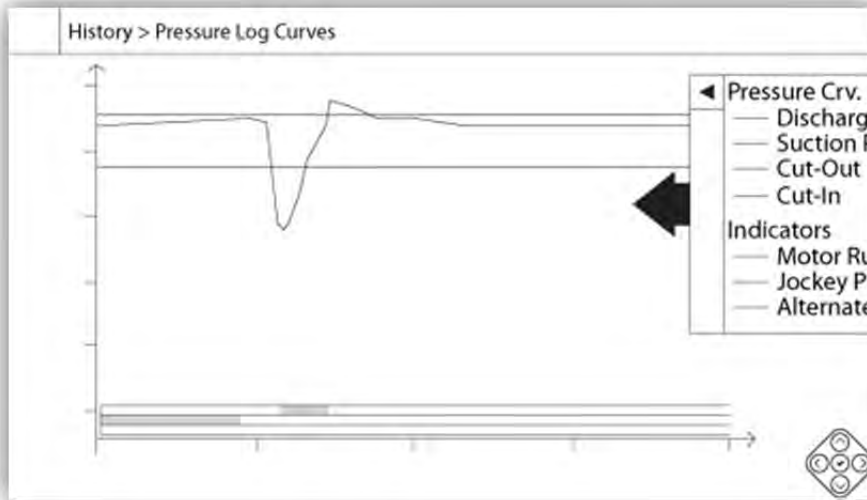

The vertical axis represents the pressure in the actual unit selected. Its scale is dynamic and will resize depending on

the highest recorded value. The horizontal axis represents time and period. The left part of the horizontal axis shows the beginning of the current scope and the right part shows the end of the scope. Located just right of the axis, the total scope time is shown. The contextual navigation pad is implemented in this page. It allows for quick navigation functions, like “Zoom in”, “Zoom out”, “Rewind”, “Forward” and “Textual Mode”. As always, clicking on the Navigation Pad Icon in the lower right corner of the screen will pop-up the Navigation Pad functions specific for this page. By pressing the right or left buttons on the navigation pad, the time will shift back or forth by a quarter of the current zoom setting, allowing a quick user-friendly navigation.

The grey vertical bar with a blue arrow, located at the far right of the screen, is the legend. Clicking on it will display an accurate description of the different curves (Discharge pressure, Suction pressure when available, Cut-In and Cut-Out) with their respective colors.

Between the “0” pressure value and the horizontal axis, a short series of narrow horizontal zones are displayed. They are described in the “Indicators” section of the legend. These zones indicate when the motor was running, when a jockey pump was running and when the voltage reading is taken from the alternate side by shading small sections of the horizontal zone whenever the condition is occurring.

As indicated earlier, the “Textual Mode” is available by pressing the “Select” button on the navigation pad. This will represent the pressure logs in a table form, allowing for a more precise reading (see “Textual Mode” right below).

Textual Mode

History > Pressure Log Text

| History > Pressure Log Text | | | | | | | | | | |
|-----------------------------|------|------|------|------|------|------|------|----|----|----|
| | Date | Time | Unit | Psuc | Pdis | C.I. | C.O. | M. | JP | AS |
| 1 | | | | | | | | | | |
| 2 | | | | | | | | | | |
| 3 | | | | | | | | | | |
| 4 | | | | | | | | | | |
| 5 | | | | | | | | | | |
| 6 | | | | | | | | | | |
| 7 | | | | | | | | | | |
| 8 | | | | | | | | | | |
| 9 | | | | | | | | | | |
| 10 | | | | | | | | | | |
| 11 | | | | | | | | | | |

The “Pressure Log text” shows a table with 10 rows. The total number of rows available is 500 and the logs are sorted in chronological order. To see more logs, please download all logs on a USB Device.

Description of the columns :

- Date: Date when the log was recorded
- Time: Time when the log was recorded
- Unit: Actual pressure unit when the log was recorded
- Suc.: Suction pressure value
- Dis.: Discharge pressure value
- C.I.: Cut-In value when the log was recorded
- C.O.: Cut-Out value when the log was recorded
- M.: The cell will become green if the motor was running for that specific pressure log.
- JP: The cell will become green if the jockey pump was running for that specific pressure log.
- AS: In the case of firepump models built with an automatic transfer switch, the cell will become green if the logged phase voltages were read from the Alternate Side of the controller.

The contextual navigation pad is implemented in this page. It allows for quick navigation functions, like “Page Up”, “Page Down”, “First Page”, “Last Page” and “Graphical Mode”. As always, clicking on the Navigation Pad Icon in the

lower right corner of the screen will pop-up the Navigation Pad functions specific for this page. By pressing these buttons, the displayed rows will shift, allowing a quick user-friendly navigation.

Power Curves

Graphical Mode

History > Power Log Curves

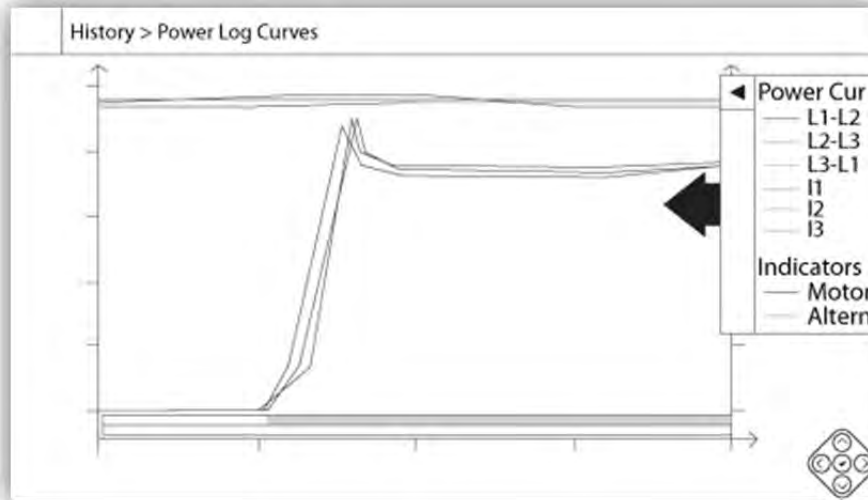

The power curve graphical mode contains two vertical axis. The first three curves, as seen on the legend, are the individual phase voltage between line 1-2, 2-3 and 3-1. In case of firepump models built with an automatic transfer switch, the phase voltages between lines represent voltage read from the alternate side of the controller when the alternate side is active. They are linked to the first axis on the left of the graph in Volt. The three last curves, as seen on the legend, are the current value of each line. They are linked to the second axis on the right of the graph in Ampere. The vertical axis scales are dynamic and will resize depending on the highest recorded value. The horizontal axis represents time and period. The left part of the horizontal axis shows the beginning of the current scope and the right part shows the end of the scope. Located just right of the axis, the total scope time is shown. The contextual navigation pad is implemented in this page. It allows for quick navigation functions, like "Zoom in", "Zoom out", "Rewind", "Forward" and "Textual Mode". As always, clicking on the Navigation Pad Icon in the lower right corner of the screen will activate the Navigation Pad with functions specific for the page. By pressing the right or left buttons on the navigation pad, the time will shift back or forth by a quarter of the current zoom setting, allowing a quick user-friendly navigation.

The grey vertical bar with a blue arrow, located far at the right of the screen is the legend. Clicking on it will display an accurate description of the different curves (L1-L2, L2-L3, L3-L1, I1, I2, I3) with their respective colors.

Between the "0" voltage value and the horizontal axis, horizontal zones are displayed. They are described in the "Indicators" section of the legend. These zones indicate when the motor was running and when the voltage reading is taken from the alternate side by colorizing small sections of the horizontal zone whenever the condition is occurring.

As indicated earlier, the "Textual Mode" is available by pressing the "Select" button on the navigation pad. This will represent the power logs in a table form, allowing for a more precise reading (see "Textual Mode" right below).

| History > Power Log Text | | | | | | | | | | |
|--------------------------|------|------|-----|-----|-----|----|----|----|----|----|
| | Date | Time | L12 | L23 | L31 | I1 | I2 | I3 | M. | AS |
| 1 | | | | | | | | | | |
| 2 | | | | | | | | | | |
| 3 | | | | | | | | | | |
| 4 | | | | | | | | | | |
| 5 | | | | | | | | | | |
| 6 | | | | | | | | | | |
| 7 | | | | | | | | | | |
| 8 | | | | | | | | | | |
| 9 | | | | | | | | | | |
| 10 | | | | | | | | | | |
| 11 | | | | | | | | | | |



The “Power Log text” shows a table with 10 rows. The total number of rows available is 500 and the logs are sorted in chronological order. To see more logs, please download all logs on a USB Device.

Description of the columns :

-Date: Date when the log was recorded

-Time: Time when the log was recorded

-L12: The phase voltages in this column represent an individual phase voltage between line 1 and line 2.

-L23: The phase voltages in this column represent an individual phase voltage between line 2 and line 3.

-L31: The phase voltages in this column represent an individual phase voltage between line 3 and line 1.

-I1: Current value of line 1

-I2: Current value of line 2

-I3: Current value of line 3

-M.: The cell will become green if the motor was running for that specific power log.

-AS: In the case of fire pump models built with an automatic transfer switch, the cell will become green if the logged phase voltages were read from the Alternate Side of the controller.

The contextual navigation pad is implemented in this page. It allows for quick navigations functions, like “Page Up”, “Page Down”, “First Page”, “Last Page” and “Graphical Mode”. As always, clicking on the Navigation Pad Icon in the lower right corner of the screen will pop-up the Navigation Pad functions specific for this page. By pressing these buttons, the displayed rows will shift, allowing a quick user-friendly navigation.

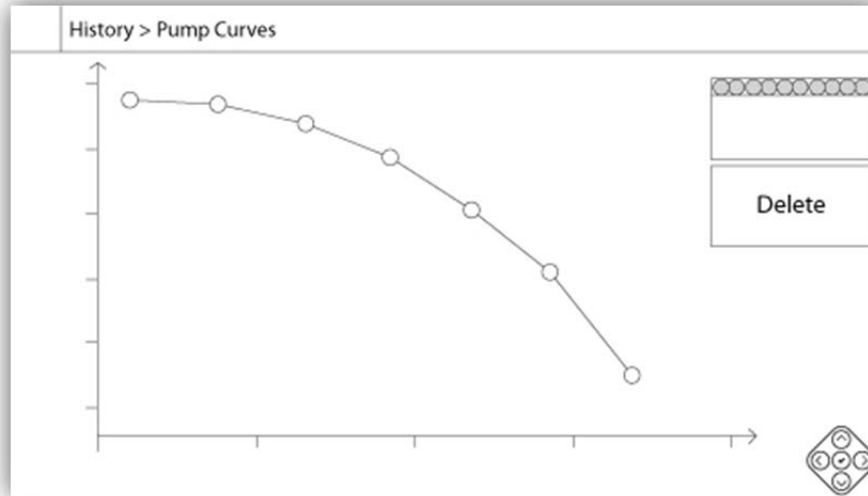

The vertical axis represents the pressure in the actual unit selected. Its scale is dynamic and will resize depending on the highest recorded value. The horizontal axis represents the flow in the actual unit selected. Its scale is dynamic and will resize depending on the highest recorded value. The contextual navigation pad is implemented in this page. It allows quick navigations functions, like "Previous" and "Next". As always, clicking on the Navigation Pad Icon in the lower right corner of the screen will activate the Navigation Pad with functions specific to that page. By pressing the right or left buttons on the navigation pad, the pump curve displayed will change, allowing a quick user-friendly navigation.

The navigation is also represented in the elements of the upper right corner of the graph. The white square indicates the date and time when the pump curve was recorded. The two arrow buttons will select the next or the previous pump curve and the "Delete" button will delete the currently selected pump curve, if the user is at least logged in as "Level 1".

Technical Documents



Pre-field Acceptance Test

**TORNATECH MODEL GPL
WITH OR WITHOUT GLU TRANSFER SWITCH
ELECTRIC FIRE PUMP CONTROLLER
PRE- FIELD ACCEPTANCE TEST
CHECK LIST**

Note: This document should be an official indication of whether or not the installation and general condition if the equipment is adequate for a field acceptance test. This document should also aid the individual responsible of executing the field acceptance test in his decision to carry out or not the controller field acceptance test of the equipment.

| Installation Check List: | | YES | NO |
|--|--|------------|-----------|
| 1 | Verify that the nameplate of the Fire Pump Controller (and Transfer Switch if supplied) corresponds with the AC voltage available. | | |
| 2 | Visual inspection for any damage to the exterior of the Fire Pump Controller (and Transfer Switch if supplied). Make sure the enclosure, alarm bell, selector switch, membrane and display are not damaged. | | |
| 3 | Verify that the Fire Pump Controller (and Transfer Switch if supplied) has been installed within sight of the pump and electric motor. | | |
| 4 | Verify that the Fire Pump Controller (and Transfer Switch if supplied) has been installed not less than 12 inches from the floor of the mechanical room. | | |
| 5 | Verify that all electrical connections to the Fire Pump Controller (and Transfer Switch if supplied) are done using conduit and connectors that meet the same NEMA rating as the enclosure. | | |
| 6 | With the Fire Pump Controller (and Transfer Switch if supplied) door open, visually inspect for any drill chips, dirt, foreign objects, loose wires, broken components and general proper electrician workmanship. | | |
| 7 | Verify that the correct Normal Power AC voltage is supplied to the controller by taking a voltage reading at the incoming terminals of the isolating switch (IS). | | |
| 8 | If applicable, verify that the correct Alternate Power AC voltage is supplied to the controller by taking a voltage reading at the incoming terminals of the alternate power isolating switch (AIS). | | |
| 9 | Verify that motor leads are connected for the corresponding starting method. | | |
| Initial Power-Up Check List: | | YES | NO |
| 1 | Controller door must be closed and latched with Normal Power Disconnecting Means handle in the OFF position. If Transfer Switch is supplied, its door must be closed and latched with Alternate Power Isolating Switch handle in the OFF position. | | |
| 2 | Verify that Emergency Start Handle is in the OFF position. | | |
| 3 | Place Normal Power Disconnecting Means handle in the ON position. If a Transfer Switch is supplied, place the Alternate Power Isolating Switch in the ON position. | | |
| 4 | Verify that the Normal Power voltage and hertz displayed on the digital screen is the same as measure in point 7 of the Installation Checklist above. | | |
| 5 | Verify that the Alternate Power voltage and hertz displayed on the digital screen is the same as measure in point 7 of the Installation Checklist above. | | |
| 6 | Verify that there is no Phase Reversal Alarm on both Normal Power and Alternate power. | | |
| Manual and Automatic Start Check List: | | YES | NO |
| Note: A manual or automatic start must only be executed if the electric motor and pump has been cleared to be started by their respective official service technicians. | | | |
| 1 | Place Normal Power Disconnecting Means handle in the ON position. If a Transfer Switch is supplied, place the Alternate Power Isolating Switch in the ON position. | | |
| 2 | Push the START push button. Motor will start. | | |
| 3 | Verify motor rotation: Before pushing the STOP pushbutton, please wait until the controller has finished its starting transition (only if controller is reduced voltage starting). | | |

| | | | |
|---|--|--|--|
| | <ul style="list-style-type: none"> If the motor rotation is correct, no adjustment is required. To correct the motor rotation, change motor connection leads 1 and 3 (A and C) at the run contactor | | |
| 4 | Verify for any alarms that would appear on the digital display screen. Correct any alarm condition. | | |
| 5 | Set Cut-Out and Cut-In settings by following the quick start-up guide or referring to the ViZiTouch documentation. You need to be logged in to modify these settings. Verify automatic start by dropping system pressure below Cut-In setting. | | |
| 6 | Stop motor by pressing the "STOP" membrane button. Note: Motor will only stop if the system pressure is above the cut-out setting. | | |

Tornatech Controller S/N: _____

Installation address: _____

Check list completed? _____ Yes _____ No

Check list completed by: _____

Company: _____

Date: _____

Witnessed By: _____

Comments: _____

Field Acceptance Test Report

**TORNATECH MODEL GPL
WITH OR WITHOUT GLU TRANSFER SWITCH
ELECTRIC FIRE PUMP CONTROLLER
FIELD ACCEPTANCE TEST REPORT**

Note: This document is the Tornatech official Field Acceptance Test report which follows the latest NFPA 20 requirements of articles 14.2.6 and 14.2.7 controller acceptance test pertinent to electric motor driven fire pump controllers with or without alternate power supplied. Tornatech strongly recommends that a pre-field acceptance verification (Tornatech document GPL-PREFAT-001-E Pre-Field Acceptance Test Check List) be completed before this official field acceptance test.

Complete this first section if it was not completed during the Pre-Field Acceptance test

Manual and Automatic Start Check List:

Note: A manual or automatic start must only be executed if the electric motor and pump has been cleared to be started by their respective official service technicians

YES

NO

| | | | |
|---|---|------------|-----------|
| 1 | Place Normal Power Disconnecting Means handle in the ON position. If a Transfer Switch is supplied, place the Alternate Power Isolating Switch in the ON position. | | |
| 2 | Push the START push button. Motor will start. | | |
| 3 | Verify motor rotation on both normal power and alternate power if applicable. Before pushing the STOP pushbutton, please wait until the controller has finished its starting transition (only if controller is reduced voltage starting). <ul style="list-style-type: none"> • If the motor rotation is correct, no adjustment is required. • To correct the motor rotation, change motor connection leads 1 and 3 (A and C) at the run contactor | | |
| 4 | Verify for any alarms that would appear on the digital display screen. Correct any alarm condition. | | |
| 5 | Set Cut-Out and Cut-In settings by following the quick start-up guide or referring to the ViZiTouch documentation. You need to be logged in to modify these settings. Verify automatic start by dropping system pressure below Cut-In setting. | | |
| 6 | Stop motor by pressing "Stop" membrane button. Note: Motor will only stop if the system pressure is above the Cut-Out setting. | | |
| | Phase Reversal Verification | YES | NO |
| 1 | Verify or simulate phase reversal on both normal and alternate power Overcurrent Protection Controller nameplate info Electric Motor nameplate info FLC: _____ A FLC: _____ A LRC: _____ A LRC: _____ A | | |

Motor Starts

| Normal Power | | YES | NO |
|---|-----------------------------|------------|-----------|
| 1 | 6 manual starts | | |
| 2 | 6 automatic starts | | |
| 3 | 6 Emergency Handle starts | | |
| 4 | 1 remote/deluge valve start | | |
| Alternate Power (with GPU Model) | | YES | NO |
| 1 | 6 manual starts | | |
| 2 | 6 automatic starts | | |
| 3 | 6 Emergency Handle starts | | |
| 4 | 1 remote/deluge valve start | | |

Field Settings:

Cut-Out Pressure: _____ Cut-In Pressure: _____

Minimum run period timer activated?

Yes: _____ Set at _____ minutes. No: _____

Sequential Start Timer?

Yes: _____ Set at _____ seconds. No: _____

Weekly Test Enabled?

Yes: _____ Start (date and time) _____ No: _____

Stop (date and time) _____

Alarm Contacts Connections:

Fire Pump Controller

Motor Run connected? _____ Yes _____ No

Power Available connected? _____ Yes _____ No

Phase Reversal connected? _____ Yes _____ No

Other contacts supplied and connected? _____ Yes _____ No

Other contacts supplied and connected?
Yes: _____

No: _____

Automatic Transfer Switch

Alternate Power Isolating Switch in OFF? _____ Yes _____ No

Transfer Switch in Normal Position? _____ Yes _____ No

Transfer Switch in Alternate Position? _____ Yes _____ No

Tornatech Controller S/N: _____

Installation address: _____

Field Acceptance Test completed?

_____ Yes _____ No

Field Acceptance completed by: _____

Company: _____

Date: _____

Witnessed By: _____

Company: _____

The undersigned witness has been made aware of the NFPA20 article 14.4 Periodic Inspection, Testing and Maintenance which stipulates that "Fire pumps shall be inspected tested and maintained in accordance with NFPA25 – *Standard for the Inspection, Testing and Maintenance of Water Based Fire Protection Systems*"

Comments: _____

Canada

Tornatech Inc.
7075 Place Robert-Joncas
Suite # 132
Montreal, Canada
H4M 2Z2
Tel.: + 1 514 334 0523
+ 1 800 363 8448
Fax: + 1 514 334 5448

U.S.A.

**USA Sales
Representative**
Tel.: + 1 513 307 6766
Fax: + 1 513 759 0509

Europe

Tornatech S.p.r.l.
Avenue Sabin 3
1300 Wavre
Belgium
Tel.: + 32 (0) 10 84 40 01
Fax: + 32 (0) 10 24 75 05

Middle East

Tornatech Fz-Llc.
P.O. Box 502221
Dubai, UAE
Tel.: + 971 50 8574639

Asia

Tornatech Pte Ltd.
49B Tuas South Ave 1
Tuas Cove Industrial Centre
Singapore 637252
Tel.: + 65 6795 8114
+ 65 6795 7823
Fax: + 65 6795 3201